

OFFICIAL BID ADVERTISEMENT

TOWN OF EAST LYME

On-Call Excavation, Pipe Installation & Drainage Services in the Town of East Lyme - 2024

Sealed bids will be received at the Public Works Office, Town Hall, 108 Pennsylvania Ave, Niantic, CT, until 2:00 PM, Wednesday, May 8, 2024 and will be publicly opened and read at that time. This bid entails providing unit cost prices for performing on call excavation and drainage repair and construction work including replacing existing and/or installing new catch basins, replacing catch basin tops and installing new drainage pipe, water pipe, and other work, as described in these contract specifications.

The specifications for the above contract are available free of charge at the East Lyme Town Hall Engineering Office. Addendums may also be posted on this contract. Inclusion of potential addendums with the bid package may be required. To be on a bidders list call (860) 691-4118 or email MWright@eltownhall.com; any questions regarding this bid should be emailed no later than the close of business on Friday, May 3, 2024 in the event an addendum needs to be sent to prospective bidders. To ensure inclusion on the bidders list, request a response email.

The Town of East Lyme reserves the right to accept or reject any or all bids; to waive any informality, or; to accept any bids deemed in the best interests of the Town of East Lyme.

This is a multiple award contract bid solicitation, where the Town of East Lyme shall utilize their own personnel and estimating resources to arrive at the lowest cost qualified Contractor based on the project type, material types and quantities, urgency and additional services and equipment required for the project.

The Town shall issue a Purchase Order for services to the lowest cost qualified Contractor per project.

TOWN OF EAST LYME

AN AFFIRMATIVE ACTION/EQUAL OPPORTUNITY EMPLOYER

All qualified applicants will receive consideration and not be discriminated against on the grounds of race, color, religion, sex, national origin, age, or handicap.

MBE/WBE AND SBE's are encouraged to bid

Note to Bidders:

- 1) Flagger(s) for Traffic Control will be provided at the Town's expense.
- 2) The Town will be responsible for temporary and final paving and asphalt curb repair associated with these bid items.

INSTRUCTIONS TO BIDDERS

1. RECEIPT AND OPENING OF BIDS:

The Town of East Lyme, hereinafter referred to as the Town, invites bids on the form attached hereto. All blanks must be appropriately filled in. Bids will be received by the Town in the Public Works Office, Town Hall, 108 Pennsylvania Ave, Niantic, CT, until 2:00 PM on Wednesday, May 8, 2024, and then publicly opened and read aloud. The envelopes containing the bids must be sealed, addressed to Town of East Lyme, CT and designated as Bid for **On-Call Excavation & Drainage Work in the Town of East Lyme - 2024**.

The Town may accept or reject any or all bids or any or all portions of bidders and take any action deemed to be in its best interest.

2. PREPARATION OF BID:

Each bid must be submitted on the prescribed form. All blank spaces for bid items must be filled in, in ink or typewritten. If you do not wish to submit a bid for an item, write "No Bid". For that item's unit price and total.

Each bid must be submitted in a sealed envelope bearing on the outside, the name of the bidder, address, and the name of the project for which the bid is submitted. If forwarded by mail, the sealed envelope containing the bid must be enclosed in another envelope addressed as specified in the paragraph above.

Documents to be submitted with the Bid

- a. Bid Form

3. QUALIFICATIONS OF BIDDER:

The Town may make whatever investigations it deems necessary to determine the ability of the bidder to perform the work, and the bidder shall furnish to the Town all information and data for this purpose as the Town may request. The Town reserves the right to reject any bid if the evidence submitted by, or investigation of, the bidder fails to satisfy the Town that the bidder is properly qualified to carry out the obligations of the contract and to complete the work contemplated therein. Conditional bids will not be accepted.

4. CONTRACTOR AVAILABILITY & NOTIFICATION

The Contractor will conform to the Public Works Department's schedule. It will be the contractor's responsibility to be available to commence working upon five (5) business days from notice to proceed from the Town. In emergencies the Contractor will make every effort to be available immediately.

The Town will attempt to contact the Contractor for a period of two (2) consecutive business days if the Contractor is deemed to be the lowest qualified Contractor for a particular project. If the Contractor cannot be reached or does not respond within the notice timeframe, the next lowest Contractor will be contacted to perform the work. The availability of a Contractor to start work within five (5) business days will be considered when selecting the “lowest available qualified” Contractor. The availability of required equipment to perform a particular project is another factor that may be considered. The work described on all purchase orders will not start until ordered by the Town. Following receipt of notice to proceed, Contractor shall begin construction within five (5) working days. Working days will be considered as Monday through Friday. Failure to start construction by 8:00 a.m. on the morning of the sixth working day following receipt of notice to proceed, either by agreement or by default, will be considered as approval of the Town to cancel the purchase order and award such work to the next qualified Contractor submitting the next lowest bid.

5. DAMAGE TO ABUTTING PROPERTIES

The Contractor shall be responsible for, and reimburse the Town, adjacent property owners and/or others for, any and all losses, damage or expense which the Town or those others may suffer, either directly or indirectly or through any claims of any person or party, for any trespass outside the spaces and rights of way provided by the Town to the Contractor, or any violation or disregard of the terms and conditions established for the use or occupancy of those rights or for negligence in the exercise of those rights. The Town may retain or deduct, or invoice the Contractor, from any sum or sums due or to become due to the Contractor such amount or amounts as may be proper to insure the Town against loss or expense, by reason of the failure of the Contractor to observe the limits and conditions of the rights of way, rights of access, etc., provided by the Town.

6. INDEMNIFICATION

The Contractor shall indemnify and hold harmless the Town against any and all damages to property or injuries to or death of any person or persons, including property and employees or agents of the Town and shall defend suits, actions or proceedings of any kind or nature including workmen’s compensation claims, of or by anyone whomsoever in any way resulting from or arising out of the operations of the contractor. Insurance coverage specified herein constitutes the minimum requirements and said requirements shall in no way lessen or limit the liability of the Contractor under the terms of the contract. The Contractor shall procure and maintain, at his/her own cost and expense, any additional kinds and amount of insurance which in his/her own judgment, may be necessary for his/her proper protection in the execution of his/her work. The Contractor agrees to well and truly save and indemnify and hold harmless the Town of East Lyme against all liability, judgments, costs and expenses which may in any way come against the Town or which may in any way result from carelessness, omission or neglect of the contractor or his/her agent, employees or workmen in any way arising or resulting from the operation in connection herewith.

7. INSURANCE REQUIREMENTS

The Contractor shall submit, before award of Contract, a copy of their certificate of insurance that is in compliance with all laws, is in the following form, and for not less than the following amounts:

COMPREHENSIVE GENERAL LIABILITY:

General Aggregate	\$ 2,000,000
Products/Completed Operations Aggregate	\$ 1,000,000
Each Occurrence	\$ 1,000,000

COMPREHENSIVE AUTOMOBILE LIABILITY

Bodily Injury	\$ 1,000,000 Each Person
	\$ 2,000,000 Each Occurrence
Property Damage	\$ 2,000,000 Each Occurrence

WORKMEN'S COMPENSATION And EMPLOYERS LIABILITY

Each Accident	\$ 100,000
Disease-Policy Limit	\$ 500,000
Disease-Each Employee	\$ 100,000

The Contractor shall designate the Town as an additional named insured in the Contractor's general liability policy, and furnish the town with a certificate or other proof of insurance which the Contractor, as part of their contract, must carry. The provisions of this paragraph shall apply to and be incorporated into any subcontracts regarding these projects between the successful bidders and their subcontractors. Work adjacent to and within State roads may require contractors to carry additional insurance according to pertinent State requirements. The Town will be responsible for CT DOT Encroachment Permits & fees. Contractor shall be insured to work in the State Right-of-Way. CT DOT must have a valid insurance certificate on file or Contractor must provide one to them.

8. ESTIMATED QUANTITIES/BALANCED BIDS

The quantities that are included in the attached Bid Form are estimated quantities. The Town reserves the right to increase and/or decrease the quantities as they see fit. Therefore, the bidder should bid on each item with reasonable relation to the probable cost of doing that work. The attention of the bidder is called to the fact that unbalancing a bid may adversely affect the contractor if certain portions of the work are increased or decreased as provided in the contract documents.

9. SAFETY

The Contractor shall comply with all requirements of the Occupational Safety and Health Act (OSHA) including wearing appropriate traffic safety vests as needed; while performing work in and/or adjacent to the right-of-way. It is the Contractor's responsibility to set up a safe traffic work zone pursuant to the latest edition of the Manual of Uniform Traffic Control (MUTCD). The cost of setting up the work zone safety pattern shall be incorporated into the unit price for the drainage installation work. This includes, at no additional cost, all signs, cones, barrels, etc. Additionally, the Contractor is responsible for letting the Town know in advance its work schedule. The Town will provide certified flaggers for traffic control when necessary, but the Contractor will be responsible for scheduling them.

10. PROJECT AREAS

The Town is intending on using this contract to install, repair, and/or replace storm drain and public water appurtenances pipe and other structures on Town owned roads and properties; including but not limited to storm drain pipe and catch basin, manhole, drywell, headwall, flared end section structures, water mains and valves. Since this is an on-call bid for services, the Contractor won't always know the extent of each project; therefore, the bid form reflects a short list of the various types of replacement and repair projects that may be considered. Prior to the work being completed, the Town will meet with the Contractor to discuss the work in detail and determine the unit price to use based on the criteria of each individual project as needed. Additional ancillary work at certain project locations may be required and may be negotiated with the successful bidders.

11. INTERPRETATION OF FORM 818

The State of Connecticut, Department of Transportation, *Standard Specifications for Roads, Bridges, Facilities and Incidental Construction, Form 818* is used as a reference for projects. Whenever the specifications in Form 818, read "Commissioner" it shall be construed to mean "East Lyme First Selectmen". Wherever the specifications read "State" it shall be construed to mean "Town of East Lyme".

SECTION 1.01 – DEFINITION OF TERMS AND PERMISSIBLE ABBREVIATIONS

Under the following Article replace the definitions with the following:

Article 1.01.01 – Definitions:

COMMISSIONER: Shall mean the Town of East Lyme, First Selectman or his/her agents.

DEPARTMENT: Shall mean the Town of East Lyme.

ENGINEER: Shall mean the Town of East Lyme Town Engineer or his/her agents.

MANAGER OF CONTRACTS: Shall mean the Town of East Lyme Public Works Director or his/her/her agents.

STATE: Shall mean the Town of East Lyme.

SECTION 1.04 – SCOPE OF WORK

Section 1.04.02 (Scope of Work – Intent of Contract) does not apply to this contract.

12. FINISHING AND CLEANING UP

In completing their operations, the Contractor shall immediately remove all surplus material, tools, and other property belonging to them, leaving the entire site & street or surroundings free and clean and in good order, at no additional expense to the Owner. The Contractor shall exercise special care in keeping the right-of-way and private lands upon which work is performed free and clean of all debris, and shall remove all tools and other property when they are not in use.

13. MEASURING OF QUANTITIES & PAYMENT

The Town will inspect the work during and following construction; material quantities will be tracked and work quality will be monitored according to Town and industry standards. Following construction, the Contractor will measure the work areas then the Contractor will submit a numbered invoice to the Town based on those mutually agreed materials and quantities. The Town will consider the submittal of intermediate invoicing for larger projects that may require extended time for the Contractor to complete. The Town will make every effort to pay the Contractor in a timely fashion. The Town reserves the right to negotiate with the successful bidder for unit costs, lump sum costs, or hourly rates for items or work that is not included in the bid list. The Town will make every effort to provide a full day's work via quantity of item installation and/or amount of equipment hours required for on-call work. The contractor is responsible to tell the Town, in writing; text, email or letter, of any work they plan to do that doesn't conform to a bid item on the Bid Form as part of a project. Any work for items not on the Bid Form shall be agreed upon separately by the Town before the work is performed in order for the contractor to get paid.

14. CONTRACT DURATION

The term of this contract will be from the time the contractor initially signs the contract until December 31, 2024. The Town reserves the right to extend the contract for one year until December 31, 2025 at the same unit prices so long as both parties mutually agree to this extension.

TECHNICAL SPECIFICATIONS

1. Call “Call Before You Dig” at 1-800-922-4455 at least 72 hours, Saturdays, Sundays, and holidays excluded, prior to excavating. A copy of the CBYD Project Reference # shall be given to Town prior to excavation.
2. The Contractor is responsible for any and all equipment necessary to complete the job. This would include all tools, forms, and employees to complete the job in a timely manner. The Town will not compensate the contractor for use or loss of equipment.
3. Once the contractor is on the job, they shall remain until the section of the work that is being asked of them is complete, unless specifically allowed otherwise by the Director of Public Works and/or his/her designee.
4. The contractor shall make sure the job site is secure at all times, especially when leaving at the end of the day.
5. Any questions pertaining to the job, including changes to grades should be addressed to the Public Works Director or his/her designee.
6. All backfilling must be done in properly compacted layers not exceeding 12” in depth after compaction. Backfill material, other than those materials depicted in the Details, shall be approved by Public Works Director or his/her designee prior to placement.
7. The contractor is responsible to correct any problems with uneven settlement of processed gravel or other material.
8. It is the Town’s intent to have a temporary layer of hot mix asphalt over all backfilled trenches by the end of each work week. The contractor is responsible for coordinating the areas that will require temporary paving at least two days prior to the end of each work week.
9. The Town reserves the right to direct the contractor at any time to stop any additional trenching/excavating work and to focus on properly backfilling areas if weather is going to become an issue.
10. If unsuitable material is found in any of the trench or excavation areas the Contractor is to let the Town know immediately. The Contractor will not be paid for “Unsuitable Soils Excavation & New Gravel Installation” if they don’t contact the Town immediately and get the Town’s approval in advance. Once the Town has confirmed that the base soils are unsuitable, then the Contractor will be required to dig down an additional 8” and remove the unsuitable materials. The Contractor is to bring in ¾” processed gravel to replace the unsuitable material and is to compact the base in the same manner as in Item #6. The cost of digging out and replacing the unsuitable materials will be paid for by the square foot of area of excavation of the unsuitable materials. If it is determined that more than 8” of ¾” processed gravel is needed for a suitable base, then the price for this work will need to be mutually agreed upon before that work is done.
11. The Contractor can dispose of catch basin tops & grates, pavement/concrete pieces, and other construction materials associated with the project at the Transfer Station, located at 91 Roxbury Road, East Lyme without fee, in accordance with proper disposal procedures.
12. The Contractor shall consider and include Mobilization and Demobilization in the Unit Prices for projects.
13. The Contractor shall achieve appropriate compaction for backfilling trenching & excavating using sufficiently sized plate compactor, jumping jack, & etc.; and included in Unit Prices.

14. Catch basin grates shall be galvanized, per CT DOT standards. Installation of storm drain pipe & catch basin components shall include road surface removal, excavation, & backfill.

Typical Installation Details:

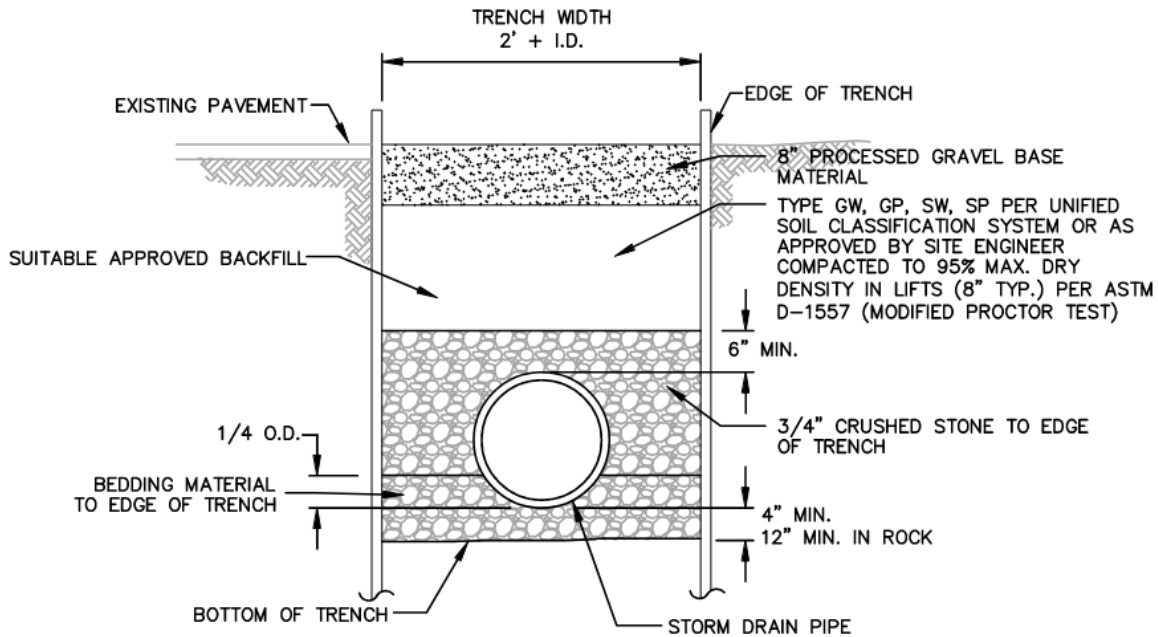

STORM DRAIN TRENCH

N.T.S.

NOTE:

1. TRENCH EXCAVATION, BACKFILL AND BEDDING MATERIAL SHALL BE INCLUDED IN THE UNIT COST OF "STORM DRAIN PIPE".

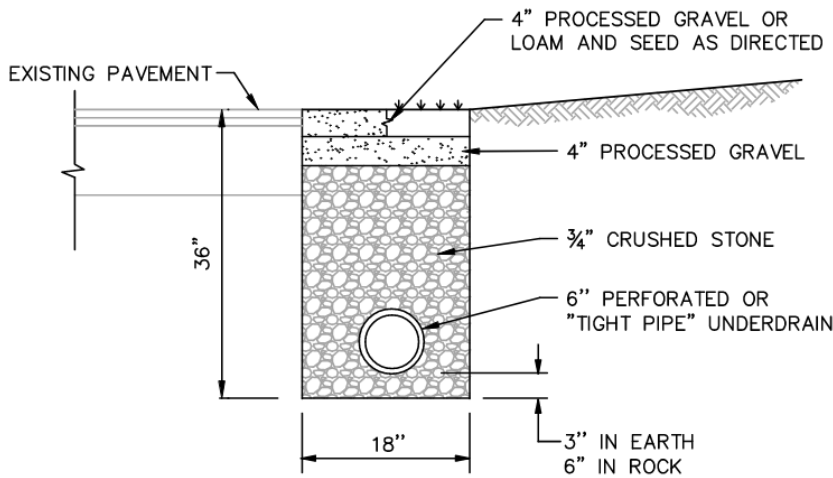

NOTES

1. PAY LIMITS FOR ROCK IN TRENCH:
18" WIDE X 36" DEEP OF ONLY ROCK REMOVED GREATER THAN 1 YARD.
2. CRUSHED STONE SHALL BE REPLACED WITH APPROVED NON-FREE DRAINING BACKFILL MATERIAL IN LOCATIONS OF "TIGHT PIPE" INSTALLATION.

TYPICAL UNDERDRAIN

N.T.S.

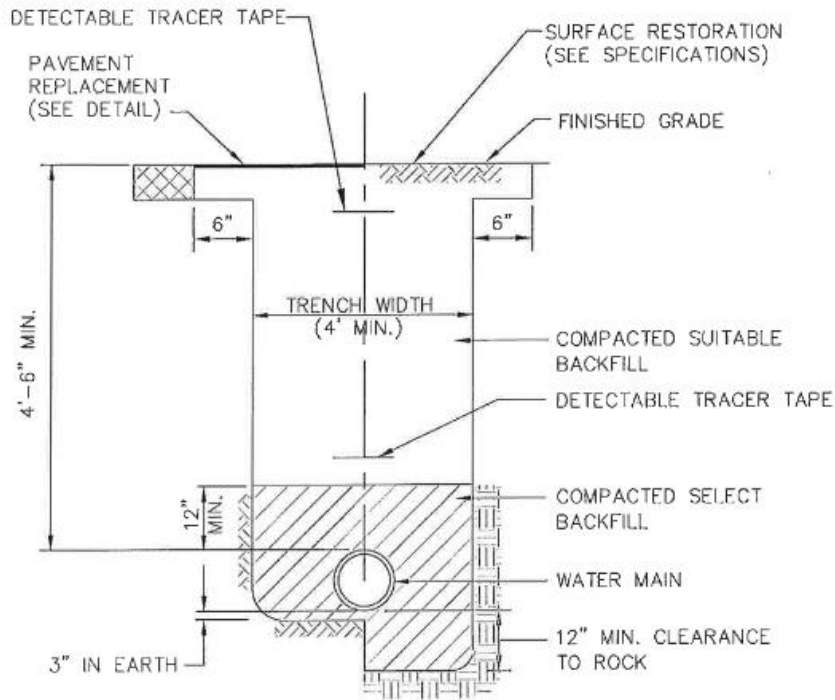

TYPICAL WATER MAIN TRENCH
N.T.S.

MAINTENANCE & PROTECTION OF TRAFFIC

Description & Construction Methods:

Maintenance and Protection of Traffic shall strictly conform to Section 9.71 of the State of Connecticut, Department of Transportation, *Standard Specifications for Roads, Bridges Facilities and Incidental Construction, Form 818*.

Whenever the Contractor's crews are working in and/or around the edge of the public roadway, then the Contractor is responsible to provide proper signage per the latest edition of the Manual of Uniform Traffic Control Devices (MUTCD). If the contractor plans on closing off any travel lanes, they shall notify the Public Works Director or his/her designee. At least one traffic lane should be kept open at all times. Any exception would need to come in writing from the Director of Public Works.

Suitable ingress and egress to all intersecting roads, abutting properties, residences, businesses, etc. shall be provided for at all times.

The Contractor shall provide and post "No Parking" signs at least 24 hours prior to working on a given area in which on street parking must be prohibited. The Contractor shall notify the East Lyme Police Department prior to posting "No Parking" signs. Signs shall be removed as soon as possible upon completion of the work in the area.

All suitable signs, barricades and other traffic devices shall be furnished, erected, moved, re-erected, maintained and removed by the Contractor to the satisfaction of the Engineer to protect the safety of the public; and the cost for these items shall be included in the unit costs.

All excavations, catch basin tops, manhole frames, road boxes and any other potential hazard to the public shall be protected by suitable barricades and signs.

The Contractor shall install temporary warning signs on exposed structures. The Contractor shall post "work-ahead" or "bump-warning" signs where appropriate.

The Town shall furnish certified traffic person(s) in accordance with Section 9.70 of the State of Connecticut, Department of Transportation, *Standard Specifications for Roads, Bridges, Facilities and Incidental Construction, Form 818* to direct traffic safely through the construction area when necessary. The flaggers will be contracted with and invoiced to the Town, but the Contractor will have to schedule them with Public Works or the Traffic Control Contractor that the Town is contracted with.

Basis of Payment:

The cost of setting up and breaking down the work zone safety pattern shall be incorporated into the unit price for the drainage installation work. This price shall include all materials, equipment, tools, and labor incidental to this item.

BID FORM

On-Call Excavation & Drainage Work in the Town of East Lyme - 2024

FROM: _____ (Bidder)

TO: Town of East Lyme
Director of Public Works
PO Box 519
108 Pennsylvania Ave
Niantic, CT 06357

The undersigned proposes to furnish through their bid price all charges, including all supervision, technical personnel, labor, materials, equipment, tools, appurtenances, services, trucking, disposal, and anything else necessary to perform and complete this Contract pursuant to the Contract specifications for the unit bid prices as listed below. Refer to appropriate Sections and corresponding materials sections of the CT DOT, *Standard Specifications for Roads, Bridges, Facilities and Incidental Construction, Form 818.*

<u>Item</u>	<u>Unit Price</u>	<u>Quantity*</u>	<u>Total</u>
Sawcut (0" to 6" Depth)	\$_____ /LF	200 LF	_____
Remove, Furnish & Install Type "C" or "C-L" Catch Basin Top & Grate and Furnish & Reset up to 3 new courses of standard sized concrete blocks	\$_____ /EA	4 EA	_____
Furnish & Install Type "C" or "C-L" Catch Basin, Including Base Slab, 2' Sump, Transition, Riser, Corbel, Top & Grate; Assuming minimum available sizes for each item mentioned above	\$_____ /EA	4 EA	_____
Repair Existing Catch Basin: Remove & Reset Top, and Furnish & Reset up to 3 new courses of standard sized concrete blocks	\$_____ /EA	4 EA	_____
Install 18" HDPE Storm Drain Pipe (0' to 4' Excavation) Refer to Detail	\$_____ /LF	60 LF	_____
Install 18" HDPE Storm Drain Pipe (4' to 8' Excavation) Refer to Detail	\$_____ /LF	30 LF	_____
Furnish & Install 6" Underdrain Refer to Detail	\$_____ /LF	300 LF	_____

Install 6-8" Ductile Iron Water Main
(4' to 6' Excavation) Refer to Detail \$_____ /LF 500 LF _____

Install 8-10" Ductile Iron Water Main
(4' to 6' Excavation) Refer to Detail \$_____ /LF 500 LF _____

Install 12"+ Ductile Iron Water Main
(4' to 6' Excavation) Refer to Detail \$_____ /LF 500 LF _____

Unsuitable Soils Excavation & New Gravel
Installation (Up to 8" Depth Additional Excavation) \$_____ /SF 1000 SF _____

**The following unit pricing is being considered
for separate jobs where the Town may require
use of said equipment/labor to complete the job:**

Trucking – Dump; with Driver
Minimum Rated Capacity: 8 yards/10 tons \$_____ /Hour 15 Hours _____

Trucking - Tri-axle; with Driver
Minimum Rated Capacity: 16 yards/18 tons \$_____ /Hour 50 Hours _____

Excavator, Compact - Hydraulic;
55 HP, 0.5 CY Bucket Capacity
(CAT 307E2, or Equivalent) \$_____ /Hour 50 Hours _____

Excavator - Hydraulic, 110 HP;
1.0 CY Bucket Capacity with Top Clamp
(John Deere 160, or Equivalent) \$_____ /Hour 20 Hours _____

Breaker "Hoe Ram" – Hydraulic, 2000 ft-lb
(HydroRam HK80, or Equivalent) \$_____ /Hour 10 Hours _____

Loader, Skid Steer; w/Operator & Attachment
Minimum Rated Capacity: 1650 lb, 50 HP
(Bobcat S510, or Equivalent) \$_____ /Hour 30 Hours _____

The attachments that the Contractor may have
will be invoiced at same unit cost

Front End Loader, Wheel;
Minimum Rated Capacity: 2.0 CY, 170 HP
(Volvo L70, or Equivalent) \$_____ /Hour 10 Hours _____

Roller - Soil Compactor;
Vibratory, 10 Ton (CAT CS54B, or Equivalent) \$_____ /Hour 20 Hours _____

Dozer – Medium, Track Type; (CAT D6K2, or Equivalent)	\$ _____ /Hour	10 Hours _____
Laborer	\$ _____ /Hour	30 Hours _____
P-7 Licensed Laborer	\$ _____ /Hour	30 Hours _____
P-7 Licensed Operator Equipment Charge**	\$ _____ /Hour	30 Hours _____
TOTAL***		_____

* These items and quantities are only estimates to be used for award purposes. The Town reserves the right to increase or decrease these quantities and/or add items as needed. Additionally, in instances where more than one piece of equipment is required for a project, the Town may choose to pay the contractor for the most costly piece of equipment used for equal duration and in lieu of other equipment hours, per working day.

** There may be circumstances where a P-7 Licensed Employee is also operating equipment while working in a P-7 capacity for pipe laying. In this case an additional charge \$/hour may be added to the equipment rate if mutually agreed by the Town and the Contractor prior to the project.

*** This total is for informational purposes only, and may not correlate to the contract awardee(s).

Note: The Town will be responsible for final paving and curb repair associated with installation.

“SAMPLE” - CONTRACT FOR – “SAMPLE”
ON-CALL EXCAVATION & DRAINAGE WORK IN THE TOWN OF EAST LYME
BETWEEN (CONTRACTOR) AND THE TOWN OF EAST LYME

THIS AGREEMENT, made this (*day*) day of (*month*), (*year*) by and between the Town of East Lyme, Connecticut, herein called the “Owner”, acting herein through its First Selectman, Mr. Dan Cunningham, and (*Contractor*) of (*Town*), (*County*) and State of (*State*), hereinafter called the “Contractor”.

WITNESSETH: That for and in consideration the payments and agreements hereinafter mentioned, to be made and performed by the OWNER and the CONTRACTOR hereby agrees with the OWNER to perform services bid under the *On-Call Excavation & Drainage Installation in the Town of East Lyme - 2024*, hereafter called the “services”, for the unit prices included on the Contractor’s Bid Form which is attached to this document.

Furthermore, all work in connection therewith, under the terms as stated in this contract; and at his/her (its or their) own proper cost and expense to furnish all the materials (excluding concrete), supplies, machinery, equipment, tools, superintendence, labor, insurance and other accessories and services necessary to complete the said services in accordance with the Official Bid Advertisement, Instructions to Bidders, Technical Specifications, and Maintenance & Protection of Traffic as prepared by the Town of East Lyme; which is hereby made part of this contract.

This agreement shall be enforceable under the laws of the State of Connecticut.

This agreement shall extend from the date it is signed until December 31, 2024. The Town reserves the right to extend the contract until December 31, 2025 at the same unit prices so long as both parties mutually agree on the extension.

The parties further agree to be contractually bound to submit themselves to the personal jurisdiction of the courts of Connecticut. The venue for any court proceeding shall be in the Judicial District for New London at New London, Connecticut.

The failure of any party to insist in any one or more instances upon performance of any of the terms or conditions of this Agreement shall not be construed as a waiver or a relinquishment of any right granted hereunder or of the future performance of any such term, covenant, or condition; but the obligations of the parties with respect thereto shall continue in full force and effect.

This Agreement cannot be changed, modified or amended in any respect except by a written instrument signed by the parties hereto. Parties acknowledge and agree that all understandings and agreements heretofore made between the parties are merged in this agreement.

This instrument contains the entire agreement of the parties. It may not be changed orally, but only by an agreement in writing signed by the party against whom enforcement of any waiver, change, modification, extension or discharge is sought.

This agreement may not be assigned by any party hereto without the written consent of the other party.

...CONTINUED

“SAMPLE” - CONTRACT FOR – “SAMPLE”
ON-CALL EXCAVATION & DRAINAGE WORK IN THE TOWN OF EAST LYME
BETWEEN (CONTRACTOR) AND THE TOWN OF EAST LYME

The OWNER agrees to pay the CONTRACTOR in current funds for the performance of the contract. The terms for the payment to the contractor are covered in the Instructions to Bidders.

IN WITNESS WHEREOF, the parties to these presents have executed this contract in the year and day first above mentioned.

This is an acknowledgement that FEMA financial assistance may be used to fund the contract. The Contractor will comply with all applicable federal law, regulations, executive orders, FEMA policies, procedures, and directives.

TOWN OF EAST LYME (OWNER)

(CONTRACTOR)

BY: _____
Dan Cunningham

BY: _____
Authorized Representative

TITLE: _____
First Selectman

TITLE: _____

DATE: _____

DATE: _____