

EAST LYME BOARD OF SELECTMEN  
PUBLIC HEARING AND REGULAR MEETING  
MINUTES  
MAY 18, 2022

PRESENT: Kevin Seery, Rose Ann Hardy, Ann Cicchiello, Dan Cunningham, Bill Weber and Anne Santoro

ALSO PRESENT: Zoning Director Bill Mulholland and Parks and Rec Director David Putnam

Mr. Seery called the meeting to order, and Mr. Norm Peck led the Pledge of Allegiance.

First Selectman Seery opened the Public Hearing regarding the adoption of an amendment to an ordinance entitled "Flood Damage Prevention" Town Ordinance Chapter 151; and he stated that the public hearing was properly noticed in The Day, on the webpage and on the signpost. He asked if anyone from the public would like to speak on said proposed ordinance amendment adoption. No one was in attendance from the public to speak on this matter, so Mr. Seery called for a motion to adjourn said public hearing.

**MOTION (1)**

Ms. Santoro MOVED to adjourn the public hearing at 7:01 p.m.  
Seconded by Ms. Cicchiello. Motion passed 6-0.

Mr. Seery called the regular meeting of the East Lyme Board of Selectmen to order at 7:01 p.m.

1b. Additional Agenda & Consent Items  
There were none.

1c. Delegations  
There were none.

1d. Approval of Minutes

Ms. Cicchiello stated that although she did not attend the May 4<sup>th</sup> regular meeting, she watched the video and is able to vote on the minutes.

**MOTION (2)**

Ms. Santoro MOVED to approve the Special Meeting Minutes of April 29, 2022, as submitted.  
Seconded by Mr. Cunningham. Motion passed 6-0.

**MOTION (3)**

Ms. Santoro MOVED to approve the Regular Meeting Minutes of May 4, 2022, as submitted.  
Seconded by Ms. Hardy. Motion passed 6-0.

1e. Consent Calendar

**MOTION (4)**

Ms. Santoro MOVED to approve the consent calendar for the regular meeting of May 18, 2022, in the amount of \$7,550.42.  
Seconded by Mr. Cunningham. Motion passed 6-0.

2a. Sidewalks Improvement Grant

DISCUSSION: Mr. Seery stated that Town Engineer Alex Klose will present information at the June 1<sup>st</sup> Board of Selectman meeting.

FILED

May 25, 2022 AT 11:43 AM/PM  
*Branka Hren ATC*  
EAST LYME TOWN CLERK

Board of Selectmen  
Regular Meeting of May 18, 2022  
1 of 4

2b. Parks and Recreation – Compost Bathrooms

DISCUSSION: Mr. Putnam handed on information on the proposed compost bathrooms, attached hereto as Exhibit #1. He explained that they have three coming that are being funded using ARP funds; one at McCook's by the upper bathrooms, and two at Hole in the Wall next to the existing facility. Summary of the product is that it is year-round, it is solar powered and will have a fan and propert to be odor free even in high heat and humidity. The wind load is rated to 120 mph. The cost is approximately \$75,000 per unit. The town receives many inquiries into adding more public restrooms downtown and at the parks and beaches, and this product may be a particularly good solution.

2c. Schedule Special Town Meeting for June 1st

**MOTION (5)**

Ms. Santoro MOVED the following call:

TOWN OF EAST LYME NOTICE OF SPECIAL TOWN MEETING. Notice is hereby given of a Special Town Meeting of the Town of East Lyme to be held on June 1, 2022 at 7:00 P.M. (E.T.) at the East Lyme Town Hall Upper Meeting Room for the following purposes:

1. To consider and act upon a special appropriation in the amount of \$25,000 to CNRE fund 32 and establish an account titled, "JAG Grant Projects," and authorize said purchase from Star Computers.
2. To consider and act upon a special appropriation in the amount of \$70,000 from CNRE Fund 32 account number 32-70-300-500-999 (Town-wide Projects) and establish an account titled, "NBB Concrete Repairs" more specifically for the structural and cosmetic repair of the concrete cracks on the Niantic Bay Boardwalk.
3. To consider and act upon a special appropriation in the amount of \$15,200 for the evaluation of the permeability of the exterior of the new public safety building, provide solution options, a cost estimate, and the production of construction plans and specifications to an account to be established in the project Fund 57 titled, "PS Building Masonry Repair" source of funding to be from Bond and Note Sale Premium Funds.
4. To consider and act upon a special appropriation in the amount of \$23,000 from CNRE Account 32-30-400-700-999 PWD – Reserve to replace the existing engine in one of the Town's garbage trucks (76EL).
5. To consider and act upon a special appropriation in the amount of \$30,489 in CNRE Fund 32 to account 32-30-400-700-999 titled, PWD Reserve for future allocation for Publics Works Department equipment.
6. To consider and act upon a special appropriation in the amount of \$15,000 in CNRE Fund 32 to an account to be established titled, "Affordable Housing Planning Grant" for the grant awarded by the State Department of Housing for professional consulting and technical services to update the Plan of Affordable Housing.
7. To consider and act upon a special appropriation in the amount of \$70,284 in CNRE Fund 32 for the purchase of a new 16 passenger and 2 wheelchair bus to be utilized at the Senior Center – Delivery expected late 2022 / early 2023 - to account number 32-40-400-700-702 "COA DOT 5310 Bus".
8. To consider and act upon a special appropriation in the amount of \$12,421 in CNRE Fund 32 to an account to be established titled "Surcharge – SB 1037", for the purpose of setting aside funds collected for the 5-cent surcharge on 50ml "nip" liquor bottles in accordance with SB 1037 – AN ACT CONCERNING SOLID WASTE MANAGEMENT.
9. To transact any other business proper to come before the meeting.

Dated at East Lyme, Connecticut, this 18th day of May 2022. EAST LYME BOARD OF SELECTMEN  
Seconded by Mr. Cunningham. Motion passed 6-0.

2d. Appointments to Boards/Commissions

**MOTION (6)**

Ms. Santoro MOVED to appoint Peter Levanti, Sr., 130 Boston Post Road #35, East Lyme, Connecticut, to serve as a Member on the Pension Board for the Town of East Lyme with a term to expire on January 8, 2024.

Seconded by Mr. Weber. Motion passed 6-0.

**MOTION (7)**

Ms. Santoro MOVED to appoint William Bundy, III, 194 Exeter Road, Lebanon, Connecticut, as Interim Fire Marshal for the Town of East Lyme.

Seconded by Ms. Cicchiello. Motion passed 6-0.

**MOTION (8)**

Ms. Santoro MOVED to appoint Rory Ghio, 104 East Shore Drive, Niantic, Connecticut, as Deputy Fire Marshal for the Town of East Lyme with a term to expire on January 5, 2026.

Seconded by Ms. Cicchiello. Motion passed 6-0.

**MOTION (9)**

Ms. Santoro MOVED to appoint James Allen, 31 Sea Spray Avenue, Niantic, Connecticut, as a Member on the East Lyme Harbor Management/Shellfish Commission with a term to expire on January 5, 2026.

Seconded by Mr. Cunningham. Motion passed 6-0.

3a. FEMA Flood Ordinance

**MOTION (10)**

Ms. Santoro MOVED to adopt a proposed amendment to an ordinance entitled: "Flood Damage Prevention" Town Ordinance Chapter 151. The effective date of the ordinance shall be ten (10) days after publication of the notice of its adoption. (Effective Date 5/31/2022).

Seconded by Mr. Cunningham. Motion passed 6-0.

4a. Ex-Officio Reports

Mr. Weber reported:

- Planning Commission:
  - POCD discussed setting up different subcommittees.
  - Discussed the potential need to schedule a public hearing on an application.

Mr. Cunningham reported:

- Parks and Recreation Commission:
  - New tent has sustained wind damage; working with the manufacturer to see if it will be covered under the warranty.
  - Continued work on the master plan for Darrows pond.
  - Beach pass sales are up from last year at this time.

Ms. Hardy reported:

- Commission on Aging has a vacancy so please talk to the First Selectman if you would be interested in volunteering for this commission.

4b. First Selectman's Report

Mr. Seery reported:

- Budget referendum is May 19<sup>th</sup> from 8am until 8pm at the Community Center.
- Starlight motel and Mobil station demolition is tentatively scheduled to begin next week.
- Be on the lookout for information from the Public Works Director regarding solar powered compost trash cans being considered.

- There has been a concern brought forward regarding the allowance of Airbnb type rentals, which are not allowed per the Zoning regulations. The Zoning Official is looking into this matter.
- Town Attorney is currently working on the paperwork needed to go along with the ARP funds disbursement; this will be moving forward soon.
- The Friends of Oswegatchie Hills held their annual meeting which included a dedication to Greg Decker, a long-time volunteer and advocate to the Friends.
- Touch A Truck is scheduled for Saturday, May 21<sup>st</sup> from 9am until 2pm; quiet hour from 9-10am.
- Annual Candlelight Vigil - Sunday, May 29<sup>th</sup> at 7:30 p.m. at Liberty Green.
- Annual Memorial Day Parade - Monday, May 30<sup>th</sup> at 2 p.m. from Columbus Avenue down Main Street.
- Long time employee Bobby Schultz retired after 47 years with the Town; May 13-20<sup>th</sup> was named "Bobby Shultz Week" in the Town of East Lyme by the First Selectman for thanks for his 47 years of dedication to the community.
- Finance Director Anna Johnson announced her retirement date as September 2, 2022.
- Met with representatives from Dominion and took a tour of the plant. Dominion has agreed to consider allowing the use of the empty building on Main Street for the bathrooms this summer season while we discuss what the steps are for this building; more information to come.
- Attended Coast Guard Academy graduation; it was a very nice event, with the Vice President in attendance and a heartfelt show of support for Ukraine.

#### 5. Communications

There were none.

#### 6. Public Comment

There was none.

#### 7. Selectman's Response

There was none.

#### 8. Executive Session

##### **MOTION (11)**

Ms. Santoro MOVED to enter into executive session at 7:50 p.m. for the purpose of discussing a real estate matter, Hathaway Farms LLC.

Seconded by Mr. Cunningham. Motion passed 6-0.

Returned to the regular meeting at 8:04 p.m. Ms. Santoro stated that no formal votes were taken in executive session.

#### 9. Adjourn

##### **MOTION (12)**

Ms. Santoro MOVED to adjourn the May 18, 2022, regular meeting of the East Lyme Board of Selectmen at 8:04 p.m.

Seconded by Mr. Cunningham. Motion passed 6-0.

Respectfully Submitted By:

*Sandra Anderson*

Sandra Anderson  
Recording Secretary

Exhibit #1

**C-11 Self Contained Recycling  
Composting Toilet Buildings**

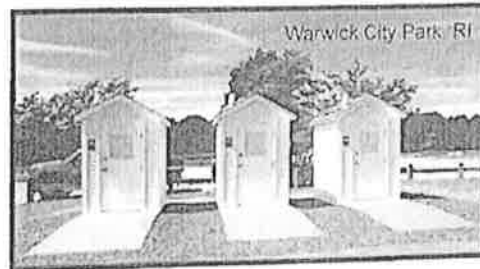
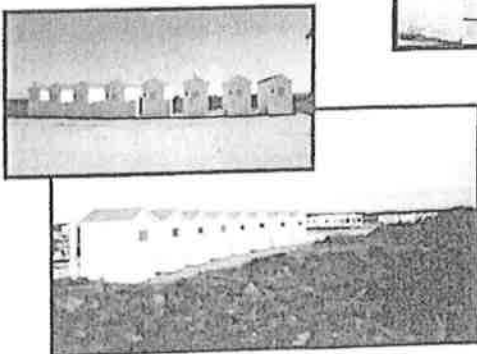
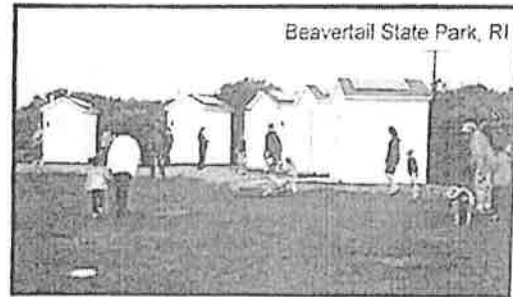
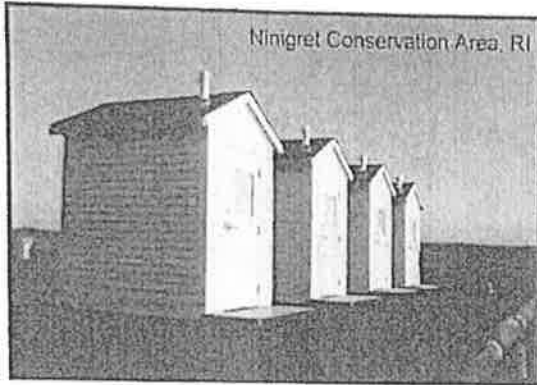

# Self-Contained Recycling Composting Toilet

1. Traditional 3-Tab Organic Asphalt Shingles
2. Ventilation Fan, AC or DC
3. Solar Panel Generating Electricity
4. Handicapped Toilet
5. Grab Bars
6. Insulation Structural Wall Panels
7. Skid-Resistant Floor
8. Translucent Lexan Window
9. Composting Chamber
10. Maintenance Area
11. Maintenance Access Lid
12. Exterior Grade Electroplated Steel Door

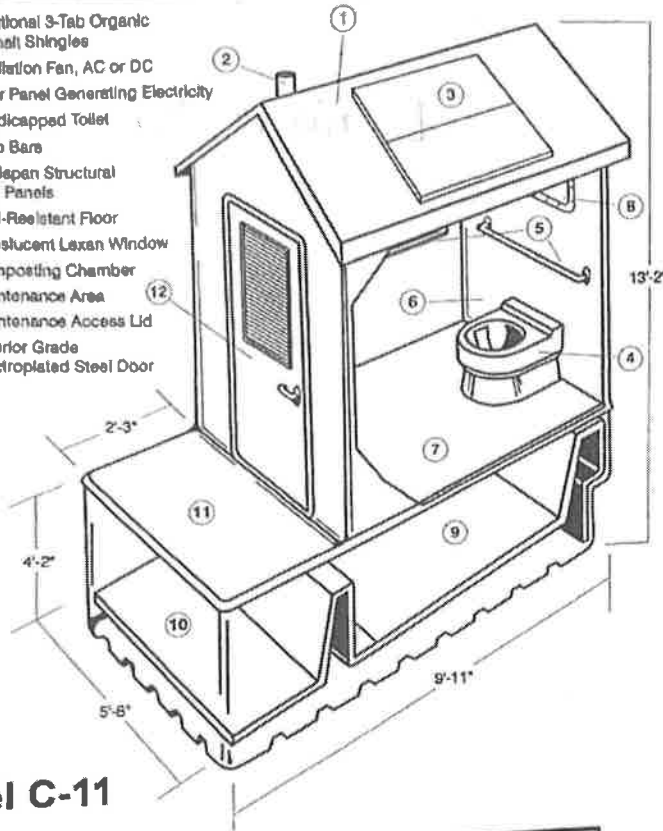

**Model C-11**

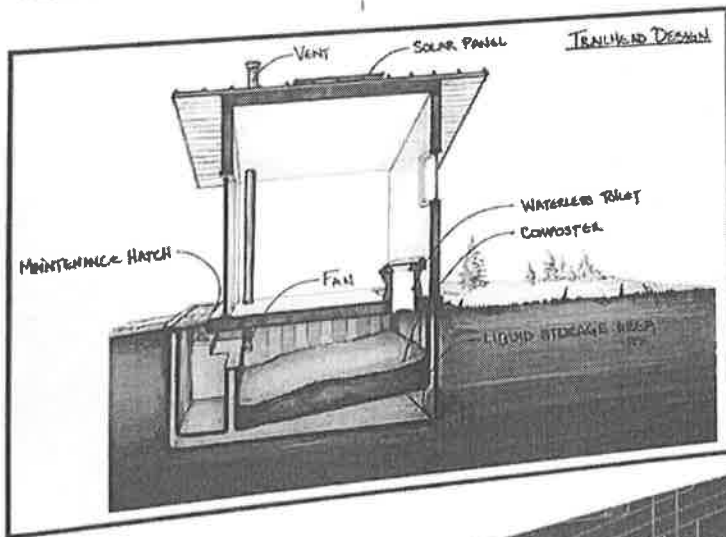
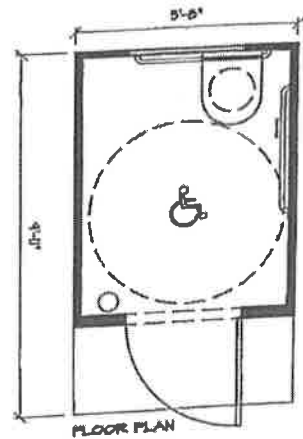

The Clivus Model C11 trailhead restroom is a heavy duty building with a self-contained composting waste treatment system. There is no discharge of waste or pollution, site disturbance is limited to the footprint of the building, and the ventilation fan can be operated with solar power if necessary. These units are all ADA accessible and can be placed in remote areas.

**clivus new england**  
incorporated

Clivus New England, Inc. • P.O. Box 127 • North Andover, MA 01845 • T: (978) 794-9400 • F: (978) 794-9444 • www.clivusne.com