

TOWN OF EAST LYME



Subdivision Regulations

Adopted: September 7, 1952

Revised Through: February 1, 2011

Effective: February 1, 2011

SECTION 1 - TITLE, PURPOSE, AUTHORITY AND APPLICABILITY.....	9
1-1 TITLE	9
1-2 PURPOSE	9
1-3 AUTHORITY	11
1-4 APPLICATION OF REGULATIONS.....	11
1-5 CONFLICTS.....	11
1-6 SEPARABILITY.....	11
1-7 AMENDMENTS	11
1-8 DATE OF ENACTION.....	11
1-9 EFFECTIVE DATE.....	11
SECTION 2 - DEFINITIONS.....	12
2-1 USAGE.....	12
2-2 WORDS AND TERMS DEFINED.....	12
SECTION 3 - GENERAL REQUIREMENTS	16
3-1 SUBDIVISION APPROVAL REQUIRED.....	16
3-2 DISCLOSURE OF BENEFICIARIES OF REAL PROPERTY HELD IN TRUST	16
3-3 PROPOSALS FOR DEVELOPMENTS USING WATER	17
3-4 PLAN OF CONSERVATION AND DEVELOPMENT.....	17
3-5 CONFORMITY WITH ZONING	17
3-6 CHANGES IN SUBDIVISION OR ZONING REGULATIONS	17
3-7 EFFECTIVE NOVEMBER 30, 2007,	17
3-8 PRIVATE STREETS OR ROADWAYS (RESIDENTIAL) PROVISIONS	17
3-8-1 Ownership.....	17
3-8-2 Maintenance and Repair.....	18
3-8-3 Miscellaneous.....	18
3-8-4 Liability.....	18
SECTION 4 – APPLICATION SUBMISSION PROCEDURE.....	19
4-1 PRE-APPLICATION SKETCH PLAN	19
4-2 APPLICATION SUBMISSION REQUIREMENTS	19

4-2-1	Application.....	19
4-2-2	Application Fee.....	20
4-2-3	Design Reports.....	20
4-2-4	Yield Plan	22
4-2-5	Subdivision Plan.....	22
4-2-6	Construction Plans	22
4-2-7	Grading Plan.....	22
4-2-8	Erosion and Sediment Control Plan	22
4-2-9	Coastal Site Plan Review Application	22
4-2-10	Base Map	23
4-2-11	Easements and Deeds	23
4-2-12	Bond or Cost Estimate	23
4-2-13	Construction Sequence Report	23
4-2-14	State Highway Agreement.....	23
4-2-15	Utility Permits and Agreements.....	23
4-2-16	Other Data and Information	23
4-3	NON-RESIDENTIAL SUBDIVISIONS REQUIRMENTS	23
4-3-1	General.....	23
4-4	PROCEDURE FOR SUBDIVISION PLAN CONSIDERATION	23
4-4-1	General.....	23
4-4-2	Date of Receipt.....	24
4-4-3	Hearing and Public Notice.....	24
4-4-4	Decision	25
4-4-5	Approval.....	25
4-4-6	Conditional Approval.....	26
4-4-7	Minutes	26
4-4-8	Endorsement.....	26
4-4-9	Filing and Recording	26
4-4-10	Revision to Construction Plans/As-Built Drawings	27
4-4-11	Certificate of Compliance.....	27
4-5	TIME LIMITATIONS	27
4-5-1	Expiration of Subdivision Approval.....	27
4-5-2	Failure to Complete Improvements.....	28
4-6	WITHDRAWAL OF APPLICATION.....	28
4-7	REVISIONS TO LOT CONFIGURATION.....	28
4-8	SIMILAR APPLICATIONS.....	29
4-9	INCOMPLETE APPLICATIONS	29
4-10	EXTENSIONS.....	29

4-11	SUBDIVISION STRADDLING MUNICIPAL BOUNDARIES	29
4-12	WAIVERS	29
4-13	APPLICABLE COMMISSION / AGENCY REVIEWS	30
4-13-1	Inland Wetlands Agency	30
4-13-2	Regional Planning Commission	30
4-13-3	Environmental Review Team (ERT) Evaluation	31
SECTION 5 – REQUIRED MAPS AND PLANS		32
5-1	PRE-APPLICATION SKETCH PLAN	32
5-2	SUBDIVISION PLAN	33
5-2-1	Subdivision Plan Submission Requirements	33
5-2-2	Subdivision Plan Requirements	33
(A)	Site Context Map	34
(B)	Natural and Cultural Resources and Site Analysis Plan	34
(C)	Resource Impact and Conservation Plan	36
(D)	Subdivision Improvements Plan/Construction Plan	36
(E)	Stormwater Management Plan.....	40
(F)	Grading Plan.....	42
(G)	Erosion and Sedimentation Control Plan	43
(H)	Studies and Reports	46
5-3	CONSTRUCTION SEQUENCE REPORT	46
5-3-1	Schedule.....	46
5-3-2	Extensions.....	47
5-3-3	Notes	47
5-4	SANITATION REPORT	47
5-5	WATER SUPPLY REPORT	48
5-5-1	Private Water Supply	48
5-5-2	Public Water Supply	48
5-6	PESTICIDE REPORT	48
5-7	COASTAL AREA MANAGEMENT (“CAM”) SITE PLAN REVIEW	48
5-8	ARCHAEOLOGICAL SURVEYS	50
5-8-1	Assessment Survey	50
5-8-2	Reconnaissance Survey.....	50
5-8-3	Intensive Survey	50
5-9	FINAL RECORD SUBDIVISION PLAN	50
5-9-1	Drafting Standards.....	50

SECTION 6 – SITE DESIGN STANDARDS	52
6-1 PURPOSES AND APPLICABILITY	52
6-1-1 Purpose	52
6-1-2 Contextual Priorities	53
6-1-3 Site Design Process.....	60
6-1-4 Density Increases.....	61
6-2 LOT DESIGN SPECIFICATIONS	62
6-2-1 Lot Size and Configuration	62
6-2-2 Health Requirements	62
6-2-3 Unbuildable Lot.....	62
6-2-4 Building Locations	63
6-2-5 Lot Access -	63
6-2-6 Energy Efficiency and Conservation	64
6-3 ADDITIONAL NON-RESIDENTIAL SUBDIVISIONS DESIGN STANDARDS	65
6-4 GENERAL IMPROVEMENTS	66
6-5 PLAN OF CONSERVATION AND DEVELOPMENT	66
6-6 SUBDIVISION NAME	66
6-7 OPEN SPACES.....	66
6-8 STORMWATER MANAGEMENT.....	66
6-8-1 General Requirements	66
6-8-2 Peak Flow and Volume Control	68
6-8-3 Groundwater Recharge Volume (GRV)	68
6-8-4 Water Quality Volume (WQV)	68
6-8-5 Requirements for Infiltration Basins/Areas	70
6-8-6 Requirements for Filtration Basins/Areas	71
6-8-7 Exemptions.....	72
6-9 FLOODING REQUIREMENTS.....	72
6-10 STREET AND ROADWAY DESIGN SPECIFICATIONS	73
6-10-1 Streets and Roadways.....	73
6-10-2 The Design of Each Street.....	74
6-10-3 Private Streets or Roadways	74
6-10-4 Subdivision Street Construction.....	77
6-10-5 Access.....	77
6-11 RESERVE STRIP	79
6-12 SIDEWALK DESIGN SPECIFICATIONS	79
6-13 STREET LIGHT SPECIFICATIONS.....	80

6-14	<i>STREET SIGN SPECIFICATIONS</i>	80
6-14-1	Street signs	80
6-14-2	House numbers.....	80
6-15	<i>STREET TREE SPECIFICATIONS</i>	80
6-15-1	Location	80
6-15-2	Size	80
6-15-3	Street Tree Easement.....	80
6-15-4	Landscaped Buffers.....	80
6-16	<i>POTABLE WATER</i>	81
6-16-1	Water Supply	81
6-16-2	Private Well Water	81
6-16-3	Public Water Supply	82
6-17	<i>UNDERGROUND UTILITIES</i>	83
6-18	<i>SURETY</i>	83
SECTION 7 - OPEN SPACES AND EASEMENTS		84
7-1	<i>PURPOSE</i>	84
7-2	<i>GENERAL</i>	84
7-3	<i>CONVEYANCE OF OPEN SPACE</i>	86
7-4	<i>LEGAL TRANSFER OF OPEN SPACE</i>	86
SECTION 8 - SUBDIVISION IMPROVEMENT SPECIFICATIONS		88
8-1	<i>GENERAL</i>	88
8-2	<i>MONUMENTS AND MARKERS</i>	88
8-3	<i>STREETS</i>	88
8-3-1	General.....	88
8-3-2	Rights-of-Way	88
8-3-3	Arterial Streets	89
8-3-4	Collector Streets.....	89
8-3-5	Residential Streets	89
8-3-6	Temporary Turnarounds.....	89
8-3-7	Dead-End Streets	90
8-3-8	Block Length	90
8-3-9	Turnaround	90
8-3-10	Minimum Grades	90
8-3-11	Centerlines.....	90
8-3-12	Intersections	91

8-3-13	Corners.....	91
8-4	STREET BASE CONSTRUCTION.....	91
8-5	STREET SURFACING.....	92
8-6	SIDEWALKS.....	92
8-7	STREET LIGHTING.....	93
8-8	STREET SIGNS.....	93
8-8-1	Posts.....	93
8-8-2	Street signs.....	93
8-8-3	Letters.....	93
8-9	DRAINAGE.....	93
8-10	WATER SYSTEM.....	94
8-11	SEWERAGE SYSTEM.....	94
8-12	UNDERGROUND UTILITIES.....	95
8-13	FIRE PROTECTION.....	95
8-14	PRIVATE STREETS AND ROADWAYS.....	96
SECTION 9 - ASSURANCES FOR COMPLETION AND MAINTENANCE OF IMPROVEMENTS		97
9-1	BONDS.....	97
9-2	EROSION AND SEDIMENTATION CONTROL AND SITE RESTORATION BOND.....	97
9-3	APPLICABILITY.....	97
9-4	BOND FORM.....	97
9-5	FAILURE TO COMPLETE IMPROVEMENTS.....	98
9-6	PARTIAL RELEASE.....	98
9-6-1	Bond Reduction Schedule for Private Roads.....	98
9-7	FINAL RELEASE.....	99
9-8	MAINTENANCE OF IMPROVEMENTS.....	99
9-8-1	Maintenance Bond.....	99
9-8-2	Snow Plowing and Other Maintenance.....	99
9-9	MAINTENANCE SERVICES TO BE PROVIDED TO SUBDIVISION RESIDENTS ON UNACCEPTED STREETS.....	100
9-9-1	Services.....	100
9-9-2	Building Permits.....	100

SECTION 10 - SUPERVISION OF IMPROVEMENTS	101
10-1 INSPECTION OF PROPOSED STREETS.....	101
10-2 PROFESSIONAL INSPECTION OF IMPROVEMENTS.....	101
10-3 INSPECTION OF PUBLIC WATER SYSTEM.....	101
10-4 INSPECTION OF EROSION SEDIMENT CONTROLS.....	101
10-4-1 Inspections.....	101
10-4-2 Variations	102
SECTION 11 - ENFORCEMENT.....	103
11-1 GENERAL ENFORCEMENT.....	103
11-2 ENFORCEMENT OF EROSION AND SEDIMENT CONTROLS	103
11-2-1 Violations.....	103
11-2-2 Cease and Desist Orders	104
APPENDICES.....	105
APPENDIX A – Typical Road Cross Section.....	106
APPENDIX B – Reserved for Future Use	107
APPENDIX C – Site Testing	108
APPENDIX D – Standard Details	110
APPENDIX E – Application Fee Calculation Sheet.....	121
APPENDIX F – Declaration of Restrictions and Covenants.....	122
APPENDIX G – Signature Block for Final Mylars.....	125

SECTION 1 - TITLE, PURPOSE, AUTHORITY AND APPLICABILITY

1-1 TITLE – These Regulations of the East Lyme Planning Commission shall be known and may be cited as the “East Lyme Subdivision Regulations”.

1-2 PURPOSE – These Regulations are adopted to promote and ensure the orderly development of land within the town so that the land, when subdivided, can be used for building purposes without danger to health and safety and for the following specified purposes:

- (1) To protect and provide for the public health, safety, and general welfare of the town.
- (2) To guide the future growth and development of the town in accordance with the Plan of Development.
- (3) To provide for adequate light, air, and privacy, to secure safety from fire, flood and other danger, and to prevent overcrowding of the land and undue congestion of population.
- (4) To protect the character and the social and economic stability of the town and to encourage the orderly and beneficial development of the municipality.
- (5) To protect and conserve the value of buildings and improvements upon the land, and to minimize conflicts among the uses of land and buildings.
- (6) To guide public and private policy and action in order to make proper provision for transportation, surface drainage, water supply, sewage disposal, schools, parks, playgrounds, recreation, and the public requirements and facilities, and in areas contiguous to brooks, rivers, or other bodies of water subject to flooding, including tidal flooding, that proper provision shall be made for protective flood control measures.
- (7) To provide the most beneficial relationship between the uses of land and buildings and the circulation of traffic throughout the municipality, having particular regard to the avoidance of congestion in the streets and highways, and the pedestrian traffic movements appropriate to the various uses of land and buildings, and to provide for the proper location and width of streets and building lines.
- (8) To establish reasonable standards of design and procedures for subdivisions and re-subdivisions, in order to further the orderly layout and use of land, and to ensure proper legal descriptions and monumenting of subdivided land.
- (9) To ensure that public facilities and services are available and will have a sufficient capacity to serve the proposed subdivision.
- (10) To prevent the pollution of air and water; to assure the adequacy of drainage facilities; to safeguard the water table; and to encourage the wise use and

management of natural resources throughout the town in order to preserve the integrity, stability, and beauty of the community and the value of the land.

- (11) To provide for open spaces and environmental protection through the most efficient design and layout of the land, including the use of Conservation Development by Design subdivision, while preserving the density of land as established in the zoning ordinance of the municipality.
- (12) To preserve the natural beauty and topography of the town and to ensure appropriate development with regard to these natural features.
- (13) To encourage energy efficient patterns of development and land use, use of solar energy and energy conservation.
- (14) To ensure that proposed streets are in harmony with existing or officially proposed streets and arranged and constructed so as to provide an adequate and convenient system for the present and prospective traffic needs.
- (15) To provide that proper provision shall be made for soil erosion and sedimentation control.
- (16) To carefully manage the use, development and preservation of the coastal area so as to protect and enhance coastal resources and water dependent use opportunities.
- (17) To conserve and protect the historic and cultural resources of the Town including but not limited to historic structures and sites and archeological sites.
- (18) To conserve and protect the natural resources of the Town including but not limited to areas of unusual scenic beauty, significant trees and stone walls, areas of ecological importance and areas of interrelated natural systems such as stream belts, "flood plains", wetlands, vernal pools, aquifers and wildlife corridors.
- (19) To protect and preserve the waters within the Town of East Lyme from non-point sources of pollution and flooding through the proper management of stormwater flows and minimization of suspended solids, pathogens, toxic contaminants, heavy metals, petroleum hydrocarbons, nitrogen and floatable debris to these flows transported by stormwater and discharging to wetlands and watercourses within East Lyme. Water is a valuable natural, economic, recreational, cultural and aesthetic resource. The protection and preservation of ground and surface water is in the public interest and essential to the health, welfare and safety of the citizens of East Lyme. As such, changes to land cover due to development without proper consideration of stormwater impacts can permanently alter the hydrologic response of local watersheds and potentially increase stormwater runoff rates and volumes, which in turn has the potential to increase flooding, stream channel erosion, sediment transport and deposition and impact water quality. Increases to impervious surfaces associated with development have been directly linked to the degradation of water quality.

- (20) To incorporate Low Impact Development (LID) techniques into the site and facility design, where possible and appropriate. Low Impact Development is a design strategy with the goal of maintaining or replicating the pre-development hydrologic regime through the use of design techniques to create a functionally equivalent hydrologic site design. Hydrologic functions of storage, infiltration, and ground water recharge, as well as the volume and frequency of discharges are maintained through the use of integrated and distributed small-scale stormwater retention and detention areas, reduction of impervious surfaces, the lengthening of run-off flow paths and flow time. Other strategies include the preservation and protection of environmentally sensitive features such as riparian buffers, wetlands, steep slopes, valuable (mature) trees, floodplains, woodlands, and highly permeable soils.
- 1-3 AUTHORITY** – Pursuant to the authority conferred by Chapter 126, Connecticut General Statutes, 1958 Revision, as amended, the Planning Commission of the Town of East Lyme adopts the regulations controlling the subdivision and re-subdivision of land.
- 1-4 APPLICATION OF REGULATIONS** – These Regulations shall apply to any owner or the agent of any owner of any land located within the Town of East Lyme who subsequent to the effective date of these Regulations subdivides or re-subdivides land as defined by these Regulations.
- 1-5 CONFLICTS** – These Regulations are not intended to interfere with, abrogate, or annul any other ordinance, rule or regulation, statute, or provision of law. Where any provision of these Regulations imposes restrictions different from those imposed by any other provisions of these Regulations or any other ordinance, rule or regulation, or other provision of law, whichever provisions are more restrictive or impose higher standards shall control.
- 1-6 SEPARABILITY** – If any part or provision of these Regulations or application thereof to any person or circumstances is adjudged invalid by a court of competent jurisdiction, such judgment shall not affect or impair the validity of the remainder of these Regulations or the application thereof to other persons or circumstances.
- 1-7 AMENDMENTS** – These Regulations may be amended by the Commission after a public hearing on said amendment(s).
- 1-8 DATE OF ENACTION** – Subdivision regulations for the Town of East Lyme first came into effect on September 9, 1952.
- 1-9 EFFECTIVE DATE** – The effective date of these Regulations shall be September 9, 1952, as amended.

SECTION 2 - DEFINITIONS

2-1 USAGE

- (1) The numbers, abbreviations, terms, and words used in these Regulations shall be used, interpreted, and defined as this section provides.
- (2) Unless the context clearly indicates to the contrary, words used in the present tense include the future tense; words used in the plural number include the singular; the word "herein" means "in these Regulations"; the word "Regulations" means "these Regulations"; words of the masculine gender include correlative words of the feminine and neuter genders.
- (3) A "person" includes a corporation, a partnership, and an incorporated association of persons such as a club; "shall" is always mandatory; a "building" includes a "structure"; a "building" or "structure" includes any part thereof; "used" or "occupied" as applied to any land or building shall be construed to include the words "intended, arranged or designed to be used or occupied"

2-2 WORDS AND TERMS DEFINED

- 2-2-1** **Applicant** – The subdivider or his agent or successor in interest that has signed the subdivision application.
- 2-2-2** **Application** – An application for the approval of a proposed subdivision or re-subdivision as provided in Section 4-2.
- 2-2-3** **Back Lot** – In a conventional subdivision design, a lot that lacks adequate street frontage and is accessible by a permanent access-way of the same ownership. Lots created using Conservation Design Development which have less than the required average frontage shall not be considered back lots as long as the average frontage requirement for the entire subdivision is met.
- 2-2-4** **Cluster Development Subdivision** – A building pattern of concentrating units on a particular portion of a parcel so that at least one-third of the parcel remains as open space to be used exclusively for recreational, conservation and agricultural purposes.
- 2-2-5** **Commission** – The Planning Commission of the Town of East Lyme.
- 2-2-6** **Conservation Design Development Subdivision** - A controlled-growth land use development that adopts the principle for allowing limited sustainable development while protecting the area's natural environmental features in perpetuity, including preserving open space, landscape and vista, protecting farmland or natural habitats for wildlife, and maintaining the character of rural communities. In East Lyme this uses the cluster development concept and extends it to consider the land areas most suitable for development to produce a more attractive, creative and efficient use of the land.

- 2-2-7 **Conventional Subdivision** – A subdivision of land in which all lots meet the minimum area and dimensional requirements of the Zoning Regulations for the district in which the subdivided parcel is located, without application of the open space/ cluster development provisions of those regulations.
- 2-2-8 **Driveway** - A narrow stretch with a smoothed or paved surface, made for traveling by motor vehicle, carriage, etc., between two or more points leading from a street or other thoroughfare to a building, house, garage, etc.
- 2-2-9 **Lot** - A plot or parcel of land occupied or capable of being occupied by one principal building and the accessory buildings or uses customarily incidental to it, including open spaces as are required by these regulations. In the case of multiple dwellings, institutional or commercial buildings, a group of buildings under the same ownership may be considered as occupying a lot.
- 2-2-10 **Planning Director** – The planner who represents the Commission in the implementation of its Regulations.
- 2-2-11 **Pre-Application Sketch Plan** – A Sketch Plan submitted by the applicant as a diagrammatic basis for informal discussion with the Planning Commission or Staff regarding the design of a proposed subdivision
- 2-2-12 **Private Residential Street** – A dedicated travel way owned in fee or in common which is not a portion of any building lot and which is restricted from public use. It does not serve the public as a whole nor function within the Town’s overall comprehensive transportation policy. Private streets are designed solely for the convenience of the residential properties they serve and to provide access to and from local and other public streets. A private street is subject to the restriction that such street shall not be offered to, accepted by, or maintained by the Town of East Lyme.
- 2-2-13 **Public Sewerage System** – A sewerage system with a collection and treatment facility approved by the State of Connecticut Department of Environmental Protection and East Lyme Water and Sewer Commission.
- 2-2-14 **Public Water System** – A water system from a common water supply or distribution system; or any water supply provided by the East Lyme Water and Sewer Commission.
- 2-2-15 **Record Subdivision Plan** – The record subdivision plan, drawing or drawings, prepared for filing in the Office of the Town Clerk subsequent to Commission approval.
- 2-2-16 **Reserve Strip** – Land controlling access to an area dedicated or to be dedicated for public use.

- 2-2-17** **Re-subdivision** – A change in a map of an approved or recorded subdivision or re-subdivision if such change (a) affects any street layout shown on such map, or (b) affects any area reserved thereon for public use, or (c) diminishes the size of any lot shown thereon and creates an additional building lot, if any of the lots shown thereon have been conveyed after the approval or recording of such map, pursuant to Chapter 126, Section 8-18, of the Connecticut General Statutes, as amended. A re-subdivision shall not include the use of an approved subdivision lot less than three (3) acres in size for the construction of a town road.
- 2-2-18** **Right-of-Way** – An area dedicated to public or private use for pedestrian and vehicular access or public utilities.
- 2-2-19** **Sale** – A voluntary transfer of title, including easements involving substantially all of the interest in the land, long term (e.g. 50 year) leases, gifts, devises and transfers for security purposes.
- 2-2-20** **Special Erosion Control Area** – That portion of a lot, which lies within fifty (50) feet of one or more of the following natural resources:
- (1) Tidal wetlands, as defined by Section 22a-29 of the Connecticut General Statutes and as delineated on the tidal wetlands maps for the Town of East Lyme prepared by the Connecticut Department of Environmental Protection, or as more specifically determined to exist by in-field inspection.
 - (2) Water courses, as defined by the Inland Wetlands and Water Courses Regulations of the Town East Lyme and as delineated on the Inland Wetlands and Water Courses Map of the Town, or as more specifically determined to exist by in-field inspection, including: rivers, streams, brooks, lakes, ponds, freshwater marshes, swamps and bogs.
 - (3) Beaches, dunes, and coastal bluffs and escarpments, as defined by Section 22a-93 of the Connecticut General Statutes and delineated as to their approximate location on the Coastal Resource Maps for the Town of East Lyme prepared by the Connecticut Department of Environmental Protection.
- 2-2-21** **Street** - Shall include any public or private roadway located within a right-of-way designed, maintained, and used as a thoroughfare in accordance with the laws of the State of Connecticut and the ordinances of the Town of East Lyme, or recorded in the office of the East Lyme Town Clerk if constructed or accepted before the passage of state and local regulations.
- (1) **Arterial Street** – A street providing for through traffic movement between areas and across the town.

- (2) Collector Street – A street intended to move traffic from residential and light residential streets, and which is intended to accommodate presently or at any future time traffic other than that of the immediate neighborhood.
- (3) Dead End Street – A street having only one intersection with a through street, and having a turn-around entirely surrounded on its frontage with separate lots.
- (4) Dead End Street (Temporary) – A street having only one intersection with another street and designed to be extended into adjoining undeveloped land, with a temporary turn-around.
- (5) Local Street – A street intended to provide access to other roads from individual residential properties
- (6) Loop Street – A two-way street that intersects itself and has only one access point on a through street
- (7) Light Residential Street – A street intended to provide access to other roads from individual residential properties and to accommodate an average daily traffic volume less than 400 vehicles. Classification of streets as residential or light residential shall be based on the number of dwelling units having direct access to the street, the number of vehicle trips per day generated by each dwelling unit as estimated by the Institute of Traffic Engineers, and the projected volume of through traffic.
- (7) Residential Street – A street intended to provide access to other roads from individual residential properties and to accommodate an average daily traffic volume between 400 and 1500 vehicles.
- (9) Through Street – A street which intersects on each end at two (2) different locations with another street or streets and is part of a network of streets, which are similarly, interconnected, each having two (2) separate outlets.

2-2-22 Street Frontage – The linear distance between the side lot lines of a lot measured at the street line.

2-2-23 Subdivider – Any person who shall layout for the purpose of sale or building development any subdivision or part thereof.

- 2-2-24 **Subdivision** – The division of a tract or parcel of land into three (3) or more parts or lots made subsequent to the adoption of subdivision regulations by the Commission (September 9, 1952), for the purpose, whether immediate or future, of sale or building development, expressly excluding the development for municipal, conservation, or agricultural purposes, and includes re-subdivisions, pursuant to Chapter 126, Section 8-18 of the Connecticut General Statutes, as amended.
- 2-2-25 **Subdivision Plan** - A subdivision plan, drawing or drawings, prepared for review by the Commission, prior to Commission approval.
- 2-2-26 **Town Engineer** – The engineer who represents the town Planning Commission in the implementation of its regulations.
- 2-2-27 **Town Plan of Conservation and Development** – A plan for guiding the development of East Lyme and which is adopted by the Planning Commission, in accordance with Section 8-23 of the Connecticut General Statutes.
- 2-2-28 **Work** – All physical improvements required by the approved plan, other than the staking out of lots, and includes but is not limited to the construction of streets, storm drainage facilities and water and sewer lines, the setting aside of open space and recreation areas, installation of telephone and electric services, planting of trees or other landscaping and installation of retaining walls or other structures.

SECTION 3 - GENERAL REQUIREMENTS

- 3-1 **SUBDIVISION APPROVAL REQUIRED** – No subdivision of land shall be made until a plan for such subdivision has been approved by the Commission. Any person, firm, or corporation making any subdivision of land without the approval of the Commission shall be fined not more than \$500 per lot sold or offered for sale or so subdivided.

Subsequent to the submission of an application and prior to the approval of such application by the Commission, no construction or work of any kind, including any building, street or any drainage or work facility, or any significant clearing of trees or modification of the land involved in such application shall be commenced excepting work associated with site testing and surveying.

- 3-2 **DISCLOSURE OF BENEFICIARIES OF REAL PROPERTY HELD IN TRUST** – Any person who makes an application to the Planning Commission, the record title to which is held by a trustee of any undisclosed trust, shall file with said application, a sworn statement disclosing the name of the equitable owner of such real property or the beneficiary of the trust.

- 3-3 PROPOSALS FOR DEVELOPMENTS USING WATER** – As required by Section 8-25 of the Connecticut General Statutes, no proposal for development using water supplied by a company incorporated on or after October 1, 1984, shall be approved by the Planning Commission unless such company has been issued a certificate pursuant to Section 16-262m of the Connecticut General Statutes.
- 3-4 PLAN OF CONSERVATION AND DEVELOPMENT** – The Plan for subdivision shall conform to the comprehensive Plan of Conservation and Development for the Town of East Lyme adopted by the East Lyme Planning Commission.
- 3-5 CONFORMITY WITH ZONING** – All subdivision plans shall conform to the requirements of the Zoning Regulations.
- 3-6 CHANGES IN SUBDIVISION OR ZONING REGULATIONS**
- 3-6-1** Pursuant to Chapter 126, Section 8-26b of the Connecticut General Statutes, as amended, when a change in the subdivision regulations is adopted by the Planning Commission, no subdivision plan which has been approved prior to the effective date of such change, and filed or recorded with the Town Clerk, shall be required to conform to such change.
- 3-6-2** Pursuant to Chapter 126, Section 8-26b of the Connecticut General Statutes, as amended, when a change is adopted in the Zoning Regulations or boundaries of zoning districts, no lots shown on a subdivision plan for residential property which has been approved prior to the effective date of such change, and filed or recorded with the Town Clerk, shall be required to conform to such change.
- 3-7 EFFECTIVE NOVEMBER 30, 2007**, no application for residential subdivision or re-subdivision that includes construction of a town road will be accepted, considered or approved for a time period not to exceed twelve (12) months from the effective date of this amendment.
- 3-8 PRIVATE STREETS OR ROADWAYS (RESIDENTIAL) PROVISIONS**
- 3-8-1 Ownership**
- (A) The land within the Private Road right-of-way, set forth specifically for access to developed lots along the private road, shall be owned and dedicated to a Common Interest Ownership Association, in accordance with Connecticut General Statutes.
- (B) If a Common Interest Ownership Association is applicable to a proposed subdivision or resubdivision, the provisions of the Common Interest Ownership must be submitted to the Planning Commission for their approval. The legal provisions of the Common Interest Ownership Association must be submitted at the time of application.

3-8-2 Maintenance and Repair

- (A) Private streets shall be designed and constructed in accordance with the specifications found in these Regulations.
- (B) A private street is subject to the restriction that such street shall not be offered to, accepted by, or maintained by the Town of East Lyme.
- (C) The Town of East Lyme shall not be held responsible at any time for short or long term maintenance or repair of private road construction, street lights, signs, or other appurtenances.
- (D) The particular Common Interest Ownership Association being served by the private road shall be responsible for all short- and long-term maintenance and/or repair of the private road. The Association shall provide adequate proof to the Planning Commission that proper Association fees will be collected on a periodic, continuous basis from Association members. Adequate proof shall include but not be limited to provisions for road maintenance and repair inclusive of normal or emergency conditions. Provisions shall consider the useful life of the private road and replacement costs at the end of the useful life. Provisions shall consider routine costs for mandatory winter snow removal and ice control, along with minimum yearly inspections or a time frame acceptable to the Association and reports made by an appropriate professional submitted to the Common Ownership Association for their use to determine road conditions.

3-8-3 Miscellaneous

- (A) Private roads shall be subject to the same requirements governing bonding as public roads in these regulations.
- (B) Private roads shall be subject to the same inspection requirements set forth for public roads found in these regulations.
- (C) Existing private roads may be extended or intersected by new private roads. However, the new road extensions or new intersecting roads shall become part of the original Common Interest Ownership Association. The Association shall be required to meet all legal, liability and economic requirements stated in these regulations for the combined proposed new and existing private road layout.

3-8-4 Liability

- (A) The Common Interest Ownership Association shall maintain a liability policy which protects the Association against accidental damages and claims.
- (B) The liability policy shall hold the Town of East Lyme harmless against claims arising from damages happening on or caused by the private road.

SECTION 4 – APPLICATION SUBMISSION PROCEDURE

4-1 PRE-APPLICATION SKETCH PLAN - Any person intending to subdivide land in the Town of East Lyme shall present a pre-application sketch plan to the Commission or Staff for informal review prior to preparing the official subdivision plan. Presentation of the sketch plan is intended to facilitate general consideration of factors and problems affecting development of the land to be subdivided and to indicate that basic requirements can be met prior to incurring engineering, application and legal costs in connection with the proposed subdivision. No fee or application form is required for presentation and review of a pre-application sketch plan.

Presentation of the pre-application sketch plan shall not constitute an application within the meaning of Title 8, Chapter 126 of the Connecticut General Statutes, as amended and as the same may, from time to time, be amended, and the staff review of said pre-application plan and comments, if any, shall not be deemed to be official "action" or "decision" within the meaning of said Title and Chapter. The pre-application sketch plan procedure shall in no way bind, bar or stop the Commission from taking any action it deems fit and making any decision it deems advisable upon filing of an application.

4-2 APPLICATION SUBMISSION REQUIREMENTS – In order to make formal application for approval of a subdivision, the applicant shall submit the following:

4-2-1 Application – The original application form and copies of all maps, plans, profiles, reports, documents, and data required by these Regulations shall be submitted to the Town Planning Department with the application fee as follows:

- (a) 12 copies of the application form;
- (b) 12 copies of the Design Reports submitted in accord with Section 4-2-3;
- (c) 12 copies of all maps, plans, and profiles as required by Section 4 -2-4 through 4 -2-12;
- (d) 12 copies of the subdivision and the surrounding properties within 500 feet of the subject property on 11"x 17" paper at a scale of not less than 1 inch = 200 feet.

The date of receipt of such application shall be determined in accordance with the Connecticut General Statutes and as detailed below. The application for approval of a subdivision shall be made in writing on forms prescribed by the Commission.

If the owner, applicant, or subdivider has made previous application for subdivision of the subject parcel which was denied, a brief discussion identifying how the new proposal differs from previous applications shall be provided as part of the application. Application forms are available at the East Lyme Town Hall in the Department of Planning and on the Town of East Lyme website www.eltownhall.com. The application shall be signed by the applicant and the record owner of the property if different than the applicant.

4-2-2 Application Fee – Application fees shall be in accord with Section 2 of the Town Ordinance Establishing Schedule of Fees for Inland Wetlands Agency, Planning, and Zoning Commissions as may be amended from time to time and attached hereto as APPENDIX E – Application Fee Calculation Sheet.

4-2-3 Design Reports - All applications for subdivision or re-subdivisions shall be accompanied by the following reports and maps unless individually waived by the Planning Commission:

(A) Natural and Cultural Resources and Site Analysis Plan at an appropriate scale showing the following:

1. **Accurate topography**, mapped from field survey or partial survey coordinated with other surveys, at a contour interval of not less than 2-foot intervals.
2. **Slope analysis**, based on the above survey, showing average slopes of 25% or greater as measured in 40 foot increments.
3. **Soils mapping** locating the extent of the various soils on the site consistent with the soil classifications of the New London County Soil Survey, including delineation by a Certified Soil Scientist of all wetland soil types.
4. **Accurately delineated flood plains**, showing the boundaries and extent of the “100 year flood hazard area” as determined from official mapping prepared for the Federal Flood Insurance Administration.
5. **The extent of any stratified-drift aquifers** underlying the site, determined from hydrologic mapping published by the U.S. Geologic Survey but refined to show estimated boundaries of direct recharge areas and estimated depths to maximum water table.
6. **Generalized types of vegetation** on the site, such as deciduous forests, coniferous forests, brush land, pastures, farmlands and grassland meadows, with boundaries clearly shown for each.
7. **Drainage basin boundaries and areas**, locating the approximate watershed extent for all significant streams and drainage channels, from topography as mapped above.

8. **Significant development**, including all existing paved roads, wood roads, trails, stone walls, driveways, right-of-ways, easements, utility lines, buildings and structures including old foundations & animal pens, paved areas, storm drainage systems, wells, septic systems, and other waste disposal areas.
 9. **Landmark and Asset Trees** (trees determined by the Tree Warden to be of great age, rarity or scenic enrichment or trees of 18 or more inches in diameter measured 4 ½ feet above ground level). Species to be noted by name and drip-line circumferences shown.
 10. **Unique scenic features**, such as (but not limited to) streams, waterfalls, ponds, habitats, vernal pools, marshes, ravines, ledge outcrops, cliffs, caves, rock shelters, ridge lines and distant views, vistas, graves and/or burial grounds.
 11. **Areas of archaeological sensitivity and historical significance** as shown on maps available in the Planning Department and/or from the Archaeological Survey required by Section 4-2-3(B) of these Regulations.
 12. **Any areas identified on the “State and Federal Listed Species and Natural Communities Map”** indicating possible presence of endangered species.
- (B) **Archaeological Survey** meeting the performance criteria described in the Environmental Review Primer for Connecticut’s Archaeological Resources and as specified in Section 5-8 of these Regulations.
- (C) **Biological Survey** if conducted as a requirement of a Natural Diversity Database Review and/or any recommendations from DEP for avoiding or minimizing impacts to species of special concern and significant natural communities.
- (D) **Soil Scientist’s Report** if one has been prepared in support of an application for review by the East Lyme Inland Wetlands Agency.
- (E) **Pesticide Report** - For lands that were at one time classified as farm land in accordance with Section 12-107c of the Connecticut General Statutes or other commercial use involving regular application of pesticides, a report detailing the site history and an evaluation of the potential human health impacts resulting from the past application of pesticides at the site shall be submitted. The report and method of evaluation shall conform to the requirements of Section 5-6.
- (F) **Traffic Report** - For all subdivisions of 25 lots or more and all non-residential subdivisions, a traffic report shall be required. Where the Commission deems it necessary, a traffic report may be required for any other subdivision.

- (G) **A Sanitation Report** in conformance to Section 5-4 of these regulations.
 - (H) **A Water Supply Report** in conformance to Section 5-5 of these regulations.
 - (I) **A Stormwater Management Plan** in accordance with Section 5-2-2(E) of these Regulations.
 - (J) **An Open Space Report** consisting of a narrative indicating how the proposed Open Space dedication meets the objectives outlined in Section 7-2 and the proposed method of conveyance in accord with Section 7-3. Any letters from organizations stating their willingness to accept Open Space as required in Section 7-3-1 and draft legal documents required in Section 7-4 shall be included. The report shall reference a separate Open Space Plan included in the Record Subdivision Maps showing any improvements proposed to the Open Space areas.
- 4-2-4 **Yield Plan** - A yield plan showing a conventional lot and street layout conforming to the zoning and subdivision regulations including a demonstration of minimum area of buildable land requirements in Section 1.38 of the Zoning Regulations. The plan shall be at the same scale as the Existing Features and Site Analysis Map.
- 4-2-5 **Subdivision Plan** - A subdivision plan shall be submitted with the application and shall conform to all of the requirements of Section 5-2 of these Regulations.
- 4-2-6 **Construction Plans** - Plan and profile drawings and cross sections and prints or copies thereof, of all proposed streets, storm drains, sanitary sewers, catch basins, manholes, ditches, watercourses, headwalls, water mains and appurtenances, community wells and pump houses, sidewalks, gutters, curbs, bridges, culverts, and other structures and improvements required by these Regulations shall be submitted with the application and shall conform to all the requirements of Section 5-2-2 (D) of these Regulations.
- 4-2-7 **Grading Plan** - A grading plan shall be submitted with the application and conform to all requirements of Section 5-2-2(F) of these Regulations.
- 4-2-8 **Erosion and Sediment Control Plan** - An erosion and sedimentation control plan shall be submitted for activity creating a disturbed area cumulatively greater than one-half acre in size in conformance with the requirements of Section 5-2-2(G) of these Regulations.
- 4-2-9 **Coastal Site Plan Review Application** - If the subdivision or any portion thereof is located within the coastal boundary, as defined by Section 22a-94 of the Connecticut General Statutes, and as depicted on the coastal boundary map for the Town of East Lyme, a coastal site plan review application shall be submitted in accordance with Section 5-7 of these Regulations and Sections 22a -105 through 22a-109 of the Connecticut General Statutes.

- 4-2-10 **Base Map** - The base map used to determine watershed and drainage patterns shall be submitted.
- 4-2-11 **Easements and Deeds** - Copies of all easements and deeds necessary to carry the subdivision plan into effect, conforming to the requirements of these Regulations, including instruments proposed to be executed or delivered after approval of the application shall be submitted.
- 4-2-12 **Bond or Cost Estimate** - An estimate of the cost of construction of all subdivision improvements shall be submitted. Estimates shall be made by an engineer licensed as a Professional Engineer in the State of Connecticut in a form acceptable to the Town Planner and Town Engineer. In addition, test borings or deep test pits may be required at the discretion of the Town Engineer to determine the substrata in the areas of the rights-of-way, so that when a bond is set, the cost of ledge removal can be included. The results of said test shall be furnished in a soils report prepared by a licensed Professional Engineer.
- 4-2-13 **Construction Sequence Report** - A schedule for the completion of improvements shall be submitted with the application and conform with Section 5-3.
- 4-2-14 **State Highway Agreement** - A copy of any Agreement made with the State Department of Transportation of any street intersection with the State Highway or where a storm drain joins with a State Highway shall be submitted.
- 4-2-15 **Utility Permits and Agreements** - Copies of proposed agreements with utility companies shall be submitted.
- 4-2-16 **Other Data and Information** - May be required from the applicant in order to establish that the proposed subdivision complies with the requirements of these Regulations.

4-3 NON-RESIDENTIAL SUBDIVISIONS REQUIRMENTS

- 4-3-1 **General** – A nonresidential subdivision shall be subject to all the requirements of site plan approval set forth in the Zoning Regulations. Site plan approval and nonresidential subdivision plan approval may proceed simultaneously. A nonresidential subdivision shall be subject to all the requirements of these Regulations, and shall conform to the East Lyme Plan of Conservation and Development and Zoning Regulations.

4-4 PROCEDURE FOR SUBDIVISION PLAN CONSIDERATION

- 4-4-1 **General** – The formal application shall be submitted to the Town Planning Department on a form approved by the Commission. The procedure in Section 4-4 of these Regulations shall be followed by the Commission in the process of reaching a decision on the application.

- 4-4-2 Date of Receipt** - The receipt date of a formal application shall be the date of the next regularly scheduled meeting of the Planning Commission immediately following the day of submission to the Commission, or thirty-five (35) days after submission, whichever is sooner.
- 4-4-3 Hearing and Public Notice** – Public hearings shall be held on applications for all re-subdivisions and all subdivisions of ten (10) or more lots. The Commission may hold a public hearing on any subdivision application if it deems that the public interest might best be served by so doing. When a formal application is submitted to the Commission and a hearing is held, such hearing shall commence within sixty-five (65) days after receipt of such application, and shall be completed within thirty-five (35) days after such hearing commences. Notice of any public hearing shall be given as required by Section 8-26 of the Connecticut General Statutes. Every applicant shall be afforded the opportunity to appear before the Commission. In addition to notice of hearing by publication, public notice of application for subdivision or re-subdivision shall be made as follows:
- (A) Notification of Adjacent Property Owners – Each application for subdivision or re-subdivision for which a public hearing is held shall include a list, prepared by the applicant, of the names and addresses of the owners of all land included within the application and of all properties 200 feet or less distant there from, all as shown on the most recent records on file in the Town of East Lyme’s Tax Assessor’s Office. The applicant shall mail notification of said pending application to at least one owner of each such property not more than 15 days nor less than 2 days before the date set for the public hearing, by transmitting the text of the public hearing notice as provided by the Commission. Evidence of such mailing, in the form of United States Post Office Certificates of Mailing, shall be submitted for inclusion in the record of the hearing.
- (B) Posting of Sign – At least 15 days prior to any public hearing on a subdivision or re-subdivision, or if no hearing is held, at least 15 days before a decision is rendered by the Planning Commission, the applicant shall post a sign on the premises indicating that such action is proposed. The sign shall be made of durable material 4’ by 4’ in size, and shall be firmly set at least three feet above ground surface and located so as to be clearly visible and legible from the most heavily used adjacent Town road or two-lane State Highway. The sign shall contain the following, in black block lettering not less than 3 inches in height on a white background:

PUBLIC NOTICE

This Property Proposed for:
SUBDIVISION

For information, contact Planning Department
East Lyme Town Hall

Immediately after the public hearing, or if no hearing is held, immediately after a decision is made by the Commission on the application, the sign shall be removed from the premises.

4-4-4 Decision – The Commission may approve, modify and approve, or disapprove the application within sixty-five (65) days after the close of the public hearing thereon, or, if no public hearing is held, within sixth-five (65) days after the receipt date thereof. Pursuant to Chapter 440 of the Connecticut General Statutes, if an application involves an activity in or affecting an inland wetland or watercourse regulated by the Conservation Commission, and the time for a decision by the Planning Commission noted earlier in this subsection would elapse prior to the thirty-fifth (35th) day after a decision by the Conservation Commission, the time period for the Planning Commission decision shall be extended to thirty-five (35) days after the decision of the Conservation Commission. This provision, shall not be construed to apply to any extension consented to by the applicant.

The Commission shall approve, modify and approve, or disapprove the subdivision application by resolution, which will set forth, in detail, any conditions to which the approval is subject and the expiration date, and the reasons for approval or disapproval. Failure of the Commission to act thereon shall be considered as an approval, and a certificate to that effect shall be issued by the Commission on demand except as provided in Section 22a-105(f) of the Connecticut General Statutes.

4-4-5 Approval – The Commission, after the public hearing, if any, shall give approval to the application if it finds that the application, plans and documents conform to the requirement of these Regulations. Such approval shall be conditioned upon presentation of suitable easement and deeds as applicable, as specified in Section 10, and shall be conditioned upon completion of all required subdivision improvements. In lieu of completion of the improvements, prior to the final approval of a plan, the Commission may accept a guarantee of performance in the form of a bond or deposit, as specified in Section 9 of these Regulations. When approval is granted, conditioned upon the filing of a bond with the Commission, such bond shall be filed prior to the endorsement of the plan.

In granting approval, the Commission may attach such conditions that it deems necessary to modify the subdivision map, plans, or documents, and to preserve the purpose and intent of these Regulations.

4-4-6 Conditional Approval - In lieu of completing the required subdivision improvements or posting a bond for the improvements as provided in Section 9, the Commission may grant a Conditional Approval. Such approval shall be conditioned upon:

- (A) The actual construction, maintenance and installation of any improvements or utilities prescribed by the Commission, evidenced by a Certificate of Completion issued by the Town Engineer and approved by the Commission, or;
- (B) The provisions of a bond, in accordance with Section 9 of these Regulations, in a form acceptable to the Town of East Lyme and amount acceptable to the Town Engineer and approved by the Commission. A Declaration of Restrictions and Covenants RE: Sale or Transfer of Subdivision Lots in the form prescribed by these Regulations in Appendix F shall be filed on the Land Records.

Upon occurrence of either of the events described in (1) or (2) above, the Commission shall grant Final Approval and authorize the Chairman or Secretary to sign a release of the Restriction of Sale.

Any conditional approval shall lapse two (2) years from the date it is granted, provided the applicant may apply for an additional period of one (1) year. No more than eight (8) extensions of one (1) year each may be granted. Any person, firm or corporation who, prior to such final approval, sells or offers for sale, any lot subdivided pursuant to a conditional approval shall be fined not more than five hundred (\$500) dollars for each lot sold or offered for sale.

4-4-7 Minutes – The Commission shall state the grounds for its decision within its minutes.

4-4-8 Endorsement – If the Commission shall approve a plan, or modify and approve a plan, its approval with the date thereof, together with a statement of any modifications applying to such approval, shall be endorsed on the plan and signed by its Chairman or Secretary on behalf of the Commission. Final molars shall contain a signature block as shown in Appendix G.

4-4-9 Filing and Recording - All approved subdivision plans shall be delivered to the applicant for filing or recording not less than thirty days after the time for taking an appeal from the action of the Commission has elapsed, and in the event of an appeal, not less than thirty days after the termination of such appeal by the dismissal, withdrawal or judgment in favor of the applicant.

Any subdivision plan, upon approval by the Commission, shall be filed or recorded by the applicant in the office of the Town Clerk within ninety days of the expiration of the appeal period specified under Section 8-8 of the Connecticut General Statutes, or in the case of an appeal, within ninety days of the termination of such appeal by dismissal, withdrawal or judgment in favor of the applicant, except that the Commission may extend the time for such filing for two additional periods of ninety days.

No such plan shall be recorded or filed by the East Lyme Town Clerk until its approval has been endorsed thereon by the Chairman or Secretary of the Commission. The filing or recording of a subdivision plan without such approval shall be void.

Upon approval of the plan, the original Mylar, 7 copies and a digital copy in AutoCAD R14 format or an approved equal shall be submitted for signature within the time period specified by the Planning Commission.

4-4-10 Revision to Construction Plans/As-Built Drawings – Any revisions of the approved construction drawings must be approved by the Town Engineer. Such revisions shall be incorporated on as-built construction plans. A separate as-built Mylar of the construction plans at a scale of one (1) inch equals forty (40) feet, shall be submitted to the East Lyme Water Department showing the location of all water mains and appurtenances with location ties to all main line valves and house service shut-off valves. Three (3) ties shall be drawn for each valve and properly dimensioned from permanent visual objects such as catch basins, hydrants, utility vaults, manholes, etc. An as-built plan, scale 1"= 40' of the subdivision streets shall be submitted to the East Lyme Planning and Water Department. All underground utilities shall be shown.

4-4-11 Certificate of Compliance - Before release of any subdivision bond, or before the Commission endorses any record subdivision map to permit filing with the Town Clerk when no subdivision bond has been posted, the applicant shall present a statement and a copy of the as-built construction plans, each signed and sealed by a Professional Engineer licensed to practice in the State of Connecticut certifying that all required subdivision improvements have been completed as shown on the subdivision plans, together with a statement from the Town Engineer reflecting that the public improvements have been completed.

4-5 TIME LIMITATIONS

4-5-1 Expiration of Subdivision Approval - Any person, firm or corporation making any subdivision of land shall complete all work in connection with such subdivision within five (5) years after the approval of the plan for such subdivision pursuant to Chapter 126, Section 8-26c of the Connecticut General Statutes, as amended. The Commission's endorsement of approval on the plan

shall state the date on which such five-year period expires. The subdivider or his successor in interest may apply for and the Commission may grant one or more extensions of the time to complete all or part of the work in connection with such subdivision, provided the time for all extensions shall not exceed ten years from the date the subdivision was approved. If the Commission grants an extension of an approval, the Commission may condition the approval on a determination of the adequacy of the amount of the bond or other surety furnished under Section 9, securing to the municipality the actual completion of the work.

4-5-2 Failure to Complete Improvements - Failure to complete all work within such five (5) year period in addition to any extensions granted by the Commission shall result in automatic expiration of the approval of such plan provided the Commission shall file on the land records of the town notice of such expiration and shall state such expiration on the subdivision plan on file in the office of the Town Clerk. No further lots shall be conveyed in the subdivision except with approval by the Commission of a new application for subdivision of the subject land. If lots have been conveyed during such period, as granted by the Commission, not to exceed ten (10) years, the Commission shall call the bond or other surety on such subdivision to the extent necessary to complete the work required to serve those lots.

4-6 WITHDRAWAL OF APPLICATION

4-6-1 At any time prior to final action by the Commission on any application, the applicant may withdraw such application by filing with the Commission, in writing, a formal request to that effect.

4-6-2 If approval of an application has been granted by the Commission, the applicant may, at any time prior to filing the approved plan with the Town Clerk, return such approved plan to the Commission with a written request for cancellation of such approval, and such cancellation of the plan shall be noted thereon.

4-6-3 No fees shall be refunded upon withdrawal.

4-7 REVISIONS TO LOT CONFIGURATION

4-7-1 Any change in the geometrical configuration of a lot or lots on an approved subdivision map filed and recorded with the Town Clerk shall be subject to review and approval by the Director of Planning for conformance with these regulations. If the proposed revision(s) results in substantially different on-and-off-site impacts, the plan shall be forwarded to the Planning Commission for approval.

- 4-7-2** Upon approval by the Planning Commission or the Director of Planning, a map showing the revision must be filed with the Town Clerk signed by the Chairman or Secretary of the Commission or Director of Planning with the date of approval noted thereon.
- 4-8 SIMILAR APPLICATIONS** – The Commission shall not be required to consider an application for approval of a subdivision while another application for subdivision of the same or substantially the same parcel is pending before the Commission.
- 4-9 INCOMPLETE APPLICATIONS** - The Commission has the authority to determine whether a submission constitutes a complete application in accordance with the requirements of these Regulations. If after reviewing a submission, the Commission finds the application to be incomplete in any material respects, it may vote to deny the application for failure to satisfy the requirements of these Regulations, after the applicant has been offered the opportunity to withdraw the application. If the application is withdrawn, the applicant will be requested to submit the additional, necessary information. No fees shall be refunded upon withdrawal of an incomplete application.
- 4-10 EXTENSIONS** - The applicant may consent to one or more extensions of any period specified for the holding of a public hearing (65 days), completion of the public hearing (35 days), and time for decision (65 days) found in Sections 4-4-3 and Section 4-4-4 of these Regulations, provided the total extension of all such periods shall not be longer than sixty-five days.
- 4-11 SUBDIVISION STRADDLING MUNICIPAL BOUNDARIES** - Whenever access to the subdivision can be had only across land in another municipality, the applicant shall demonstrate that an access road has been legally established and that such access road is adequately improved or that a performance bond has been duly executed and is sufficient in amount to assure the construction of the access road. Lot lines shall be laid out so as not to cross town boundary lines.
- 4-12 WAIVERS** - Only as specifically authorized within these Regulations, the Commission may waive certain requirements by a three-quarters vote of all members, when it is demonstrated that strict compliance with such Regulations will cause an exceptional difficulty or undue hardship. The applicant shall submit a waiver request in writing at the time of application, and the Commission shall require a public hearing, and shall not grant a waiver unless it finds the following conditions are met:
- (1) The waiver has been requested in writing by the applicant in the application submission;
 - (2) The property for which the waiver is sought is affected by conditions, which affect the property and are not generally applicable to other land in the area;

- (3) Physical features if the property or its location causes exceptional difficulty or unusual hardship in meeting the requirements of these Regulations;
- (4) The granting of a waiver will not have a significantly adverse effect upon adjacent property, the environment, or the public health and safety;
- (5) The granting of the waiver will not be in conflict with the Plan of Conservation and Development;
- (6) Where it is proposed to vary any engineering standard contained in these Regulations, a report from the Town Engineer has been requested and considered by the Commission;
- (7) The requested waiver is the minimum deviation from the requirements of these Regulations necessary to permit subdivision of subject land.

In granting a waiver, the Commission shall state upon its record, the reasons for granting any waiver.

4-13 APPLICABLE COMMISSION / AGENCY REVIEWS

4-13-1 Inland Wetlands Agency - If an application involves land regulated as an inland wetland or watercourse under the provisions of Chapter 440 of the Connecticut General Statutes, the applicant shall submit an application to the Inland Wetlands Agency no later than the day the application is filed for subdivision or re-subdivision. The Planning Commission shall not render a decision until the Inland Wetlands Agency has submitted a report with its final decision to the Planning Commission. In making its decision, the Planning Commission shall give due consideration to the report of the Inland Wetlands Agency.

4-13-2 Regional Planning Commission – Whenever a subdivision of land is planned, the area of which abuts or includes land in the Town of East Lyme and an adjacent municipality, the Commission of each municipality shall, before approving the plan, submit it to the Regional Planning Commission. Within thirty (30) days after receiving the submitted subdivision plans, the Regional Planning Commission shall report its findings on the inter-municipal aspects of the proposed subdivision to the municipalities. Failure to submit such report back to the municipalities within thirty (30) days after transmittal shall be presumed to indicate that the Regional Planning Commission does not disapprove the proposed subdivision. The report of the Regional Planning Commission shall be advisory only.

4-13-3 Environmental Review Team (ERT) Evaluation – Subdivisions of 20 lots or more where more than 50% of the parcel(s) to be subdivided consist of environmentally sensitive resources such as wetlands, steep slopes (>25%), watercourses, flood hazard areas or ridge lines, shall be subject to an evaluation by the Eastern Connecticut Environmental Review Team. This requirement does not preclude the Commission from requesting an Environmental Review Team Evaluation for applications which do not meet the above parameters but for which concerns about environmental impacts of the development and their proper mitigation exist.

SECTION 5 – REQUIRED MAPS AND PLANS

5-1 PRE-APPLICATION SKETCH PLAN - A sketch plan shall be submitted by the applicant as a diagrammatic basis for informal discussion with the Planning Commission or Staff regarding the design of a proposed subdivision. Sketch plan submission is required by the Town as a way of helping applicants and officials develop a better understanding of the subject property and helps establish an overall design approach that respects the site's special or noteworthy features, while providing for the density permitted under the zoning regulations.

To provide a full understanding of the site's potential and to facilitate the most effective exchange with the Planning Commission or Staff, the Sketch Plan should include the following information listed below.

- (1) Name and address of the legal owner, the equitable owner, and/or the applicant;
- (2) Name and address of the professional engineer, surveyor, planner, architect, landscape architect, or site designer responsible for preparing the plan;
- (3) Graphic scale (not greater than 1" = 200 ft.; however, dimensions on the plan need not be exact at this stage) and north arrow;
- (4) Approximate tract boundaries, sufficient to locate the tract on a map of the Town of East Lyme;
- (5) Location map;
- (6) Zoning district;
- (7) Streets on and adjacent to the tract (both existing and proposed);
- (8) 100-year floodplain limits, and approximate location of wetlands, if any;
- (9) Topographic, physical, and cultural features including fields, pastures, meadows, wooded areas, trees with a diameter of fifteen inches or more, hedgerows and other significant vegetation, steep slopes (over 25%), rock outcrops, soil types, ponds, ditches, drains, dumps, storage tanks, streams within two hundred (200) feet of the tract, and existing rights-of-way and easements, and cultural features; such as all structures, foundations, walls, wells, trails, and abandoned roads;
- (10) Schematic layout indicating a general concept for land;
- (11) Proposed general street and lot layout;
- (12) In the case of land development plans, proposed location of buildings and major structures, parking areas and other improvements; and
- (13) General description of proposed method of water supply, sewage disposal, and stormwater management.

5-2 SUBDIVISION PLAN - The Subdivision Plan shall provide the name and address of the legal owner or equitable owner of the subject property, and the name and address of the applicant if not the same party, plus the following elements listed below. A deed or agreement of sale evidencing that the applicant is the legal or equitable owner of the land to be subdivided or developed shall be shown.

5-2-1 Subdivision Plan Submission Requirements - The submission requirements for a Subdivision Plan shall consist of the following elements, and shall be prepared in accordance with the drafting standards and plan requirements described herein:

- (a) Site Context Map;
- (b) Existing Resources and Site Analysis Plan;
- (c) Preliminary Resource Impact and Conservation Plan;
- (d) Subdivision Improvements Plan/Construction Plan;
- (e) Stormwater Management Plan;
- (f) Grading Plan;
- (g) Erosion and Sedimentation Control Plan;
- (h) Studies and Reports as set forth in Section 4-2 of these Regulations.

5-2-2 Subdivision Plan Requirements - The following plans and maps shall be prepared by a registered professional engineer, land surveyor, and landscape architect. All plans shall be stamped, signed and sealed and include the address, and telephone number of the engineer, land surveyor, and landscape architect responsible for its preparation. Plans shall be produced and submitted by one of the following processes: wash-off photographic polyester film, fixed line photographic polyester film, original ink drawing on polyester film or linen, or any other material approved by the public records administrator. They shall be submitted on sheets of a size not to exceed twenty-four (24) inches wide and thirty-six (36) inches long and shall be drawn to a horizontal scale of 1" = 40' and a vertical scale of 1" = 4', except that cross section drawings shall be drawn to a horizontal and vertical scale of 1" = 10 feet. The minimum size for all plan lettering shall be 80 guide "Leroy" or 3/32 inch. The original as revised shall be submitted upon approval of the subdivision. An additional two (2) copies shall be scaled in accordance with the pertinent tax map on file in the Assessor's office.

(A) Site Context Map

A map showing the location of the proposed subdivision within its neighborhood context shall be submitted. For sites under 100 acres in area, such maps shall be at a scale not less than 1" = 200', and shall show the relationship of the subject property to natural and man-made features existing within 1,000 feet of the site. For sites of 100 acres or more, the scale shall be 1" = 400', and shall show the above relationships within 2,000 feet of the site. The features that shall be shown on Site Context Maps include topography (from U.S.G.S. maps), stream valleys, wetland complexes (from maps published by the U.S. Fish & Wildlife Service or the U.S.D.A. Natural Resources Conservation Service), woodlands over one-half acre in area (from aerial photographs), ridge lines, public roads and trails, utility easements and rights of way, public land, and land protected under conservation easements.

(B) Natural and Cultural Resources and Site Analysis Plan

For all subdivisions a Natural and Cultural Resources and Site Analysis Plan shall be prepared to provide the developer and the Commission with a comprehensive analysis of existing conditions, both on the proposed development site and within 500-feet of the site. Conditions beyond the parcel boundaries may be described on the basis of existing published data available from governmental agencies, and from aerial photographs.

The Commission and its staff shall review the Plan to assess its accuracy and likely impact upon the natural and cultural resources on the property. Unless otherwise specified by the Planning Commission, such plans shall generally be prepared at the scale of 1" = 100' or 1" = 200', whichever would fit best on a single standard size sheet (24" x 36"). The following information shall be included in this Plan:

- i. A vertical aerial photograph enlarged to a scale not less detailed than 1 inch = 400 feet, with the site boundaries clearly marked.
- ii. Topography, the contour lines of which shall generally be at two-foot intervals, determined by photogrammetry (although 10-foot intervals are permissible beyond the parcel boundaries, interpolated from U.S.G.S. published maps). The determination of appropriate contour intervals shall be made by the Planning Commission, which may specify greater or lesser intervals on exceptionally steep or flat sites. Slopes between 15 and 25 percent and exceeding 25 percent shall be clearly indicated. Topography for major subdivisions shall be prepared by a professional land surveyor or professional engineer from an actual field survey of the site or from stereoscopic aerial photography and shall be coordinated with official U.S.G.S. benchmarks.

- iii. The location and delineation of ponds, streams, ditches, drains, and natural drainage swales, as well as the 100-year floodplains and wetlands as delineated by a certified soil scientist licensed in the State of Connecticut. Additional areas of wetlands on the proposed development parcel shall also be indicated, as evident from testing, visual inspection, or from the presence of wetland vegetation.
- iv. Vegetative cover conditions on the property according to general cover type including cultivated land, permanent grass land, meadow, pasture, old field, hedgerow, woodland and wetland, trees with a caliper in excess of fifteen inches, the actual canopy line of existing trees and woodlands. Vegetative types shall be described by plant community, relative age and condition.
- v. Soil series, types and phases, as mapped by the U.S. Department of Agriculture, Natural Resources Conservation Service in the published soil survey for the county, and accompanying data published for each soil relating to its suitability for construction (and, in unsewered areas, for septic suitability).
- vi. Ridge lines and watershed boundaries shall be identified.
- vii. A viewshed analysis showing the location and extent of views into the property from public roads and from public parks, public forests, and state game lands.
- viii. Geologic formations on the proposed development parcel, including rock outcroppings, cliffs, sinkholes, and fault lines, based on available published information or more detailed data obtained by the applicant.
- ix. All existing man-made features including but not limited to streets, driveways, farm roads, woods roads, buildings, foundations, walls, wells, drainage fields, dumps, utilities, fire hydrants, and storm and sanitary sewers.
- x. Locations of all historically significant sites or structures on the tract, including but not limited to cellarholes, stone walls, earthworks, and graves.
- xi. Locations of trails that have been in public use (pedestrian, equestrian, bicycle, etc.).
- xii. All easements and other encumbrances of property, which are or have been filed on record with the office of the Town Clerk, shall be shown on the plan.
- xiii. Total acreage of the tract.

(C) Resource Impact and Conservation Plan

A Preliminary Resource Impact and Conservation Plan shall be prepared for all subdivision applications to categorize the impacts of the proposed activities and physical alterations on those resources shown on the Existing Resources and Site Analysis Plan as required under Section 5-2-2(B). All proposed improvements, including but not necessarily limited to grading, fill, streets, buildings, utilities and stormwater detention facilities, as proposed in the other Subdivision Improvements Plan documents, shall be taken into account in preparing the Preliminary Resource Impact and Conservation Plan, which shall clearly demonstrate that the applicant has minimized site disturbance to the greatest extent practicable.

- i. Using the Existing Resources and Site Analysis Plan as a base map, impact areas shall be mapped according to the following categories: (1) primary impact areas, i.e., areas directly impacted by the proposed subdivision, (2) secondary impact areas, i.e., areas in proximity to primary areas which may be impacted, and (3) designated protected areas, either to be included in a proposed Greenway or an equivalent designation such as dedication of a neighborhood park site.
- ii. This requirement for a Preliminary Resource Impact and Conservation Plan may be waived by the Planning Commission if, in its judgment, the proposed development areas, as laid out in the in the Subdivision Plan would be likely to cause no more than an insignificant impact upon the site's resources.

(D) Subdivision Improvements Plan/Construction Plan

The plan shall show the proposed layout of lots, streets, improvements, including but not limited to profile and cross section drawings of existing and all proposed streets, storm drains, water mains and appurtenances, community wells, and pump houses, sanitary sewers, catch basins, manholes, ditches, water courses, headwalls, gutters, curbs and other structures, and all contiguous land of the applicant that may be subdivided in the future, in order to allow the Commission to complete a general planning review of the proposed subdivision including its relationship to the potential future subdivision of contiguous land of the applicant. The plan shall incorporate a survey of the parcel in accordance with the standards established by the Regulations of Connecticut State Agencies, Section 20-300b through 20-300b-20 inclusive which shall be tied to the Connecticut State Plane Coordinate System by a closed traverse if land is within a distance to base control of 1,000 feet. The copies shall contain the following:

- i. **Title** - Title of subdivision, date, scale, graphic scale, north arrow, legend, town, and state. All revisions shall be indicated by date and type of change.
- ii. **Identification** - Name and address of owner of the land to be subdivided; name and address of the applicant, if different from the owner.
- iii. **Zoning District** - The zoning district or districts including overlay zones in which the subdivision is located and any zoning district boundary lines.
- iv. **Location Map** - A location map at a scale of 1" = 800' showing the location of the subdivision and proposed streets in relation to the main town streets. Street names are to be shown on the location plan and the plan is to be related by a distance to the nearest existing street.
- v. **Index Map** - An index map, if the proposed subdivision is divided into sections or is of such size that more than one sheet is required, showing the entire subdivision with lots, lot numbers, streets, street names, and delineation of areas covered by the section or sheet. The index sheet should note all pages, dates, and revisions by page. The index shall show the last revision date of any sheet of the plan.
- vi. **Wetlands and Watercourses** - Existing and proposed watercourses and ponds, conservation areas, and easements and rights-of-way; wetland soils, other land subject to potential flooding, tidal wetlands; and the location and limits of all wetlands and floodplains. For subdivisions of five (5) lots or more wetland boundaries shall be staked by a soil scientist or botanist, as applicable, and surveyed by a licensed surveyor.
- vii. **Topography** - Existing contours at an interval not exceeding two (2) feet based on field or aerial survey and using official Town of East Lyme, State, or U.S. benchmarks, which shall be noted on the plan. Existing contours shall be shown as dashed lines and proposed contours shall be shown as bolded solid lines.
- viii. **Structures** - Existing permanent buildings and structures.
- ix. **Limits of Clearing**- Principal wooded areas and/or the approximate location of all trees measured twenty-four (24) inches or greater in caliper at breast height. The proposed vegetation clearing line shall be shown along with all trees to be retained. The location of all proposed shade trees along the street shall be shown.
- x. **Soils** - Soil classifications, any ledge outcrops and existing stone walls and fences.

- xi. **Limits of Grading** - The limits of any areas proposed for re-grading by excavation or filling; and the limits of any areas proposed to be reserved and protected from excavation or filling.
- xii. **Flood Elevations** - Identification of flood elevations, zones and floodplains, as identified on the Federal Insurance Administration Flood Insurance Rate Map dated June 15, 1984, as revised.
- xiii. **Certificate of Title** - When land is to be conveyed to the town for highway purposes, a certificate of title running to the Town of East Lyme is required.
- xiv. **Energy Efficiency** - A written statement outlining how the energy efficiency and conservation provisions of Section 6-2-6 of these Regulations have been met.
- xv. **Lot Lines** - Existing and proposed property and street lines with dimensions, lot numbers, street names, adjoining property lines for a distance of 200 feet and the names of all adjacent subdivisions and property owners not part of the subdivision. For Lot lines an accurate layout of all lots with lot numbers; setback lines and minimum square; existing and proposed open space reserved for parks, playgrounds, stream protection, protection of tidal wetlands and beaches, and other open space, with dimensions, angles, bearings and curve data; square footage of all lots, open spaces, and land included in the subdivision and the total acreage of land included in the subdivision shall be shown.
- xvi. **Monuments** - Existing and proposed monuments.
- xvii. **Streets** - Accurate layout of existing and proposed streets, easements or rights-of-way; including those for utilities and drainage either on or off site, with accurate bearings and dimensions, including arc length, radii and angle of all curves. For streets, the existing and proposed grades at the center line of the street, including delineation of all vertical curves and proposed cross sections and width of pavement shall be drawn for each fifty (50) feet of the roadway and key elevations of existing adjoining streets and spot elevations showing tentative grading of proposed streets within the subdivision. Cross section drawings shall have a scale of 1-inch equals 10 feet. **In addition, a detailed drawing at a scale of 1" = 20' shall be provided for all proposed cul-de-sacs and road intersections with spot elevations every 10' around the perimeter.** Additional road sections shall be provided as required by the Commission.
- xviii. **Sidewalks and Curbing** - The location and composition of existing and proposed sidewalks, curbs, gutters and special structures.

- xix. **Culverts, Manholes, and Other Special Structures** - Detail drawings of any bridges, box culverts, deep manholes, and other special structures including the depth, invert slope and size of all pipes, ditches, culverts, manholes and catch basins; including top of grate elevations, headwalls and watercourses, and typical ditch and watercourse cross sections.
- xx. **Water and Sewer Mains and Other Appurtenances** - Location and size of existing water mains and appurtenances, community wells and pumps houses, sanitary sewers and proposed extension of the water supply and sanitary sewer lines including connections to the existing mains. All existing facilities shall be shown in dashed lines and proposed installations in heavy solid lines.
- xxi. **Utility Lines** - Proposed plan views of underground power, telephone, and TV cables shall be included in the submission. These utilities shall be installed prior to paving and located. These utilities shall be located on the as-built drawings.
- xxii. **Other Improvements** - Details of all other proposed improvements or modifications; including a statement specifying the requirements for site preparation for each lot.
- xxiii. **Erosion and Sedimentation Control** - Notation and details on erosion and sedimentation control methods to be employed (see Erosion and Sedimentation Control Plan Section 4-2-8)
- xxiv. **Computations** - Computations shall be submitted for all proposed storm sewer facilities and for structures, which are not included in Appendix E.
- xxv. **Test Pits** - Location and results of all deep test pits, percolation test holes, or other means of investigating the feasibility for subsurface sewage disposal (see Appendix C).
- xxvi. **Coastal Area Management Site Review** - If within the coastal boundary, the narrative of the Coastal Area Management Site Review in accordance with Section 5-7 of these Regulations must be submitted, and the following note must be placed on the Mylar, "Reviewed and approved by the East Lyme Planning Commission for coastal site plan review under Connecticut General Statutes Sections 22a-105 through 22a-109, as amended."

(E) Stormwater Management Plan

A Stormwater Management Plan shall be included as a part of any subdivision application. Changes to land cover due to development without proper consideration of stormwater impacts can permanently alter the hydrologic response of local watersheds and potentially increase stormwater runoff rates and volumes, which in turn has the potential to increase flooding, stream channel erosion, sediment transport and deposition and impact water quality. Increases to impervious surfaces associated with development have been directly linked to the degradation of water quality. Water is a valuable natural, economic, recreational, cultural and aesthetic resource. The protection and preservation of ground and surface water is in the public interest and essential to the health, welfare and safety of the citizens of East Lyme.

- i. The applicant's Stormwater Management Plan shall include a narrative of the objectives including potential impacts resulting from the proposal or activity and a description of the practices, techniques, structures and facilities proposed to mitigate such impacts. It shall provide, at a minimum, the following information and shall be prepared by an engineer licensed to practice in the State of Connecticut.
- ii. Existing site conditions inclusive of soil characteristics based on USDA soil surveys including soil names, map unit, erodibility, permeability, depth, texture and soil structure, and results of any on-site testing.
- iii. Existing Drainage Area Plan showing subcatchment drainage areas and analysis points with total area, groundcover, impervious surface area and runoff coefficients used to calculate pre-development peak runoff rates and volumes.
- iv. Proposed Drainage Area Plan showing subcatchment drainage areas and analysis points with total area, groundcover, impervious surface area and runoff coefficients used to calculate post-development peak runoff rates and volumes, location and description of receiving stormwater conveyance systems, surface waters, wetlands and other sensitive receptors.
- v. Proposed site conditions including description of proposed stormwater management system for construction and post-construction phases, total disturbed area, increase in impervious surface due to development, and any potential impacts to wetlands, watercourses, and groundwater on or adjacent to the site.

- vi. A description of design methodologies, hydrologic, hydraulic, and water quality computations for all practices and techniques, and structures and facilities as prescribed in Section 6-8 of these regulations.
- vii. Drawings including plan views, profiles, cross-sections, and typical details of all storm water management system components at adequate scale(s) and containing sufficient detail to clearly depict the intent of the design; details of construction and/or installation, dimensions and materials including planting and landscape plans and details associated with storm water management system components.
- viii. Structural design, geotechnical design and supporting information, as required by the Town Engineer for stormwater management system components including but not limited to, storm sewers, channels, outlet protection measures, culverts, bridges, dams, spillways, outlet worksweirs and other structures.
- ix. Location of all easements (20' width minimum) stating the specific responsibilities of the grantor and grantee as to the access and maintenance of the storm water system.
- x. Estimated cost for bonding of construction of stormwater maintenance system, including professional oversight and inspection until approval and filing of final subdivision plan.
- xi. Proposed operation, inspection and maintenance schedule program for the stormwater management system and the proposed designation of the party responsible for the operation, inspection and maintenance of the stormwater management system. The following entities may be designated as a responsible party:
 - a. A homeowner's association comprised of the owners of all the lots in the subdivision.
 - b. The owner(s) of each lot in the subdivision, who shall be jointly and severally responsible for the stormwater management system.
 - c. Any suitable alternative approved by the Commission.
- xii. If applicable, properly executed legal documents, including warranty deeds for any transfers of title to the party designated to maintain and operate the stormwater management system, shall be submitted with the final subdivision plan to be filed. All such documents shall be acceptable to the Town Attorney and the Commission and shall be filed with the East Lyme Town Clerk simultaneously with the filing of the approved final subdivision maps.

(F) Grading Plan

The grading plan shall be drawn on maps produced by one of the following processes: wash-off photographic polyester film, fixed line photographic polyester film, original ink drawing on polyester film or linen, or any other material approved by the public records administrator. They shall be submitted on sheets twenty-four (24) inches wide and thirty-six (36) inches long and to a scale of 1" = 40' and shall bear the seal of a Professional Engineer licensed to practice in the State of Connecticut. Contours and elevations shall be based on the same benchmarks as provided in Section 5-1. The minimum size for all plan lettering shall be 80 guide "Leroy" or 3/32 inch. In addition to the Mylar, the original and ten (10) copies reproduced by black and white or similar contact process shall be submitted. The grading plan may be combined with the construction plan with permission of the Commission. The grading plan shall show at least the following information:

- i.** Title of subdivision.
- ii.** Name and address of the owner of the land to be subdivided; name and address of the applicant if different from the owner.
- iii.** Date, scale, graphic scale, north arrow, town, and state.
- iv.** Layout of existing and proposed lot lines and street lines.
- v.** Existing and proposed contours shown at an interval not exceeding two (2) feet, based on field and aerial survey.
- vi.** Existing and proposed drainage and watercourses.
- vii.** Location of existing and typical location of proposed permanent buildings and structures, including well and septic system locations, in order to illustrate the feasibility of improving proposed lots.
- viii.** Locations, elevations and profiles of all test holes, test pits or borings, located in accordance with the specifications of Appendix C.
- ix.** Notations and details on erosion and sedimentation control methods to be employed.

(G) Erosion and Sedimentation Control Plan

In accordance with Sections 22a-325 through 22a-329 of the Connecticut General Statutes, soil erosion and sedimentation controls are required for any activity which would create a disturbed area of cumulatively more than one-half (1/2) acre in size. Any development creating a disturbed area within a special erosion control area, as defined in Section 2-2-13, is subject to the requirements for filing and obtaining certification of an erosion and sedimentation control plan. The purpose of the sedimentation controls is to minimize soil erosion and sedimentation that occurs as a result of rapid changes in land use resulting in the construction of residential, industrial and commercial development, and land disturbing activities associated with development. Soil erosion caused by such land use changes necessitates costly repairs to gullies, washed out fills, and roads and embankments, in addition to destroying the inherent soil capabilities to support vegetation. The sediment, upon entering water bodies and wetlands, is a major source of pollution and limits desired water quality and supply, aesthetics, recreational and fish and wildlife habitat benefits. Deposition clogs storm sewers, road ditches and may damage adjoining properties.

- i. To be eligible for certification, a soil erosion and sediment control plan shall contain proper provisions to adequately control accelerated erosion and sedimentation and reduce the danger from stormwater runoff on the proposed site based on the best available technology. As a general rule, the area disturbed at any one time shall be kept to a minimum. The principles, methods and practices necessary for certification are found in the Connecticut Guidelines for Soil Erosion and Sediment Control (2002), as amended.

Alternative principles, methods and practices may be used with prior approval of the Commission. Said plan shall contain, but not be limited to:

a. **A narrative on the site plan describing:**

1. The development;
2. The schedule for grading and construction activities including:
 - a. Start and completion dates;
 - b. Sequence of grading and construction;
 - c. Sequence for installation and/or application of soil erosion and sediment control measures;
 - d. Sequence for final stabilization of the project site.

3. The design criteria for proposed soil erosion and sediment control measures and stormwater management facilities;
4. The construction details for proposed soil erosion and sediment control measures and storm water management facilities;
5. The installation and/or application procedures for proposed soil erosion and sediment control measures and stormwater management facilities;
6. The operations and maintenance program for proposed soil erosion and sediment control measures and stormwater management facilities;
7. Identification of a designated on-site individual responsible for installation, monitoring and correction of sediment control plan requirements and authorized to take corrective actions, as required, to ensure compliance with certified plans.

b. A site plan map at a sufficient scale to show:

1. The location of the proposed development and adjacent properties;
2. The existing and proposed topography including soil types, wetlands, watercourses and water bodies; beaches and dunes, and bluffs;
3. The existing structures on the project site, if any;
4. The proposed area alterations including cleared, excavated, filled of graded areas and proposed structures, utilities, roads and, if applicable, new property lines;
5. The location of and design details for all proposed soil erosion and sediment control and stormwater management facilities;
6. The sequence of grading and construction activities;
7. The sequence for installation and/or application of soil erosion and sediment control measures;
8. The sequence for final stabilization for the development site;
9. Before and after contours at not less than 2 foot intervals;
10. Certification block entitled, "Erosion and Sedimentation Control Plan Certified by vote of the East Lyme Planning Commission on (date)" and a space for the signature of the Chairman or Secretary of the Commission;

11. Submission of the Soil Erosion and Sedimentation Control Plan shall be accompanied by a complete application form, which is available from the Town Planning Department;
12. Any other information deemed necessary and appropriate by the applicant or requested by the Commission or its agent.

c. Minimum Acceptable Standards

1. Plans for soil erosion and sediment control shall be developed in accordance with these Regulations and Appendix D using the principles as outlined in Chapters 3 and 4 of the Connecticut Guidelines for Soil Erosion and Sediment Control (1985), as amended. Soil erosion and sediment control plans shall result in a development that minimizes erosion and sedimentation during construction, is stabilized from erosion when completed, and does not cause off-site erosion and/or sedimentation;
2. The minimum standards for individual measures are those in Connecticut Guidelines for Soil Erosion and Sediment Control (1985), as amended. The Commission may grant exceptions as long as the proposed activity will not result in consequences inconsistent with the purpose of these Regulations and those standards;
3. The appropriate method from the 2002 Connecticut Guidelines for Soil Erosion and Sediment Control, as amended, shall be used in determining peak flow rates and volumes of runoff unless an alternative, equivalent method is approved by the Commission;
4. The location and boundaries of tidal wetlands, watercourses, beaches, dunes and coastal bluffs shall be shown. If an applicant disputes the designation of any part of the land as a special erosion control area, the applicant may be required to produce such information, including documentation by a soils scientist for inland wetlands or a botanist for tidal wetlands, as the Commission or its agent deem necessary, to permit an informed decision.

d. Issuance or Denial of Certification

1. The Planning Commission shall either certify that the Soil Erosion and Sediment Control Plan, as filed, complies with the requirements and objectives of this Regulation, or deny certification when the development proposal does not comply with these Regulations. Denial of certification by the Commission

of a Soil Erosion and Sediment Control Plan shall be sufficient reason for denial of the overall subdivision application;

2. Nothing in these Regulations shall be construed as extending the time limits for the approval of any application under Chapter 126 of the Connecticut General Statutes;
3. Prior to certification, any plan submitted to the Commission may be reviewed by the County Soil and Water Conservation District which may make recommendations concerning such plan; provided such review shall be completed within thirty days of the receipt of such plan by the county Soil and Water Conservation District;
4. The Commission may forward a copy of the development proposal to the Conservation Commission or other review agency or consultant for review and comment.

e. Conditions Relating to Soil Erosion and Sediment Control

1. The estimated costs of measures required to control erosion and sedimentation, as specified in the certified plan, shall be covered in a performance bond or other assurance acceptable to the Commission in accordance with the provisions specified under Section 9 of the Regulations;
2. Site development shall not begin unless the soil erosion and sediment control plan is certified and those control measures and facilities are installed and functional;
3. Planned soil erosion and sediment control measures and facilities shall be installed as scheduled according to the certified plan;
4. All control measures and facilities shall be maintained in effective condition to ensure compliance with the certified plan.

As-built plans may be required by the Planning Commission for any soil and erosion control facilities which are to be considered permanent.

(H) Studies and Reports

- i. As set forth in Section 4-2-3 of these Regulations.

5-3 CONSTRUCTION SEQUENCE REPORT

5-3-1 Schedule - A schedule for the expected completion of improvements shall be submitted and noted on the subdivision plan to specifically include the following notes:

- (A)** All improvements associated with the construction of the subdivision which involves work as defined in Section 2-2-21 affecting adjacent

property for which an easement has been acquired shall be completed within four (4) months of work begun within the easement.

- (B) All work associated with off-site improvements for this subdivision shall be completed within four (4) months of work begun on the off-site improvements associated with the subdivision. Improvements for town owned cul-de-sacs shall be exempted from this section and instead regulated by Section 8-3.
- (C) A site restoration bond for off-site improvements and improvements on adjacent properties as described in Section 9-2 will be required as part of the approval process. This bond is separate and distinct from the performance bond as described in Section 9-1 of these Regulations.

5-3-2 Extensions - The Commission may grant an extension of the provisions described in Section 5-3-1 (A) and 5-3-1 (B) for an additional period of four (4) months, if it finds that no adverse impacts on adjoining property owners is evident. No more than three (3) extensions of four (4) months each may be granted, prior to calling the bond.

5-3-3 Notes - This note may be omitted from the record subdivision plan if there is no work to be done on adjacent properties or no required off-site improvements.

5-4 SANITATION REPORT – When on-site sewage disposal is to be provided, soil testing for on-site sewage disposal systems shall be conducted in accordance with Appendix C. At least one (1) deep test pit and percolation test is required on each lot. The East Lyme Health Department must be present to witness the digging and testing or receive satisfactory certification of conduct of testing. Field testing shall be scheduled sufficiently in advance to allow for a submission of the proposed final plan to the Health Department for review at least three weeks prior to the anticipated formal submission to the Planning Commission. A copy of the proposed plan must be provided to the Health Department for review and field-testing purposes. A letter from the Health Department must be provided certifying the land to be subdivided and subdivision plans are satisfactory for on-site sewage disposal systems.

When a subdivision is to be served by the Municipal Sanitary Sewer System, a report detailing the design discharge volume, the nature of wastewater and any special pretreatment systems anticipated, as well as a description and plan of sewer connection location and any proposed sewer collection system extensions, including pump stations, shall be submitted. A letter from the Water and Sewer Commission shall be provided noting review of the proposed sanitary system and indicating accessibility and feasibility of the proposal.

When a subdivision is to be served by a public sewerage system other than the municipal system, a report shall be submitted detailing the design criteria and volume

as well as a description and plan of the proposed distribution and disposal system. Letter(s) indicating the approval of the system by the East Lyme Health Department, East Lyme Water and Sewer Commission, and State Department of Environmental Protection shall be provided. In addition, the letter from the Water and Sewer Commission shall indicate that the developer has met all the requirements of and has received approval for consideration as a public or community sewerage system in accordance with Sections 7-245 through 7-246L Connecticut General Statutes.

5-5 WATER SUPPLY REPORT - Two (2) copies of the water report shall be submitted as a part of the application. The design of the water system shall be in compliance with the requirements and the provisions of Section 6-16 of these Regulations.

5-5-1 Private Water Supply - When a subdivision is not to be served by a private water supply, a report from the Health Department shall be obtained and submitted by the applicant certifying that the land to be subdivided and the subdivision plans are satisfactory for the installation of private water supply.

5-5-2 Public Water Supply - When a subdivision is to be served by a public water supply system that will be connected to the East Lyme water distribution and transmission system, a statement shall be provided from the Water and Sewer Commission stating the impact on the existing East Lyme water system. Evidence for compliance with Section 3-3 of these Regulations shall be provided. Non-residential subdivisions and subdivisions of ten (10) or more lots shall comply with the requirements and the provisions of Section 6-16 of these Regulations.

5-6 PESTICIDE REPORT – Reports submitted in compliance with Section 4-2-3(E) of these regulations shall detail the known history of pesticide use at the site, including the types of pesticides used, application rates and the period over which such use occurred. In addition soil and groundwater testing shall be performed by qualified professionals and be of sufficient scope to reasonably evaluate potential human health impacts resulting from the past application of pesticides at the site. Soil data shall be measured against criteria established in the CT DEP’s Remediation Standard Regulations (RSR’s) for Pollutant Mobility Criteria (PMC) and Direct Exposure Criteria (DEC). Groundwater shall be sampled for pesticides via EPA Test Method 505 and meet drinking water standards. All test results evaluated shall be included in the report. Where test results show concentrations of pesticides in excess of RSR values, a remediation plan shall be included in the report and areas of remediation clearly identified on a plan.

5-7 COASTAL AREA MANAGEMENT (“CAM”) SITE PLAN REVIEW – A Coastal Site Plan Review (“CSPR”) is required for all subdivisions within the coastal boundary of the Town of East Lyme in accordance with Sections 22a-105 through 22a-109 of the Connecticut General Statutes. All applicants for subdivisions located within the coastal boundary shall file with the Commission ten (10) copies of a coastal site plan application on such form as prescribed by the Commission.

5-7-1 Pursuant to Sections 22a-105 through 22a-109 of the Connecticut General Statutes, a coastal site plan shall include the following information.

- (1) A plan showing the location and spatial relationship of coastal resources on and contiguous to the site;
- (2) A description of the entire project with appropriate plans, indicating project location, timing and methods of construction;
- (3) An assessment of the capability for the resources to accommodate the proposed use;
- (4) An assessment of the suitability of the project for the proposed site;
- (5) An evaluation of the potential beneficial and adverse impacts of the project on both coastal resources and future water-dependent development opportunities and a description of proposed methods to mitigate adverse impacts on coastal resources and water dependent uses.

The applicant shall also demonstrate that any unmitigated adverse impacts are acceptable and that such activity is consistent with the coastal policies of Section 22a-92 of the Connecticut General Statutes.

5-7-2 In accordance with Section 22a-106(b) of the Connecticut General Statutes, when determining the acceptability of a proposed subdivision's potential adverse impacts on both coastal resources and future water-dependent development opportunities, the Planning Commission shall:

- (1) Consider the characteristics of the site, including the location and condition of any of the coastal resources defined in Section 22a-93(7);
- (2) Consider the potential effects, both beneficial and adverse, of the proposed activity on coastal resources and future water-dependent opportunities, and
- (3) Follow all applicable goals and policies stated in Section 22a-92 and identify conflicts between the proposed activity and any goal or policy.

5-7-3 In accordance with Section 22a-105(e) of the Connecticut General Statutes, the Planning Commission may modify or condition the subdivision application to:

- (1) Ensure conformance with the goals and policies of Section 22a-92;
- (2) Minimize any anticipated adverse impacts on coastal resources, as defined in Section 22a-93 (15); and
- (3) Ensure that a portion of any waterfront subdivision satisfies the water-dependent use criteria of Section 22a-93(16) and 22a-93(17).

5-7-4 In accordance with Section 22a-106 (d) and (e) of the Connecticut General Statutes, the Planning Commission shall state in writing the findings and reasons for its action.

- 5-8 ARCHAEOLOGICAL SURVEYS** – Archaeological surveys shall be conducted by a professional archaeologist whose credentials are recognized by the Connecticut Historical Commission and/or State Archaeologist. A report of all surveys conducted shall be sent to the State Historic Preservation Office a minimum of 35 days prior to submission of the subdivision application to the Planning Commission.
- 5-8-1 Assessment Survey** - An Assessment Survey (sensitivity survey) shall be conducted on all land proposed for subdivision to provide a general evaluation of the archaeological potential of the property including identification of known archaeological sites, areas of severe ground disturbance, and areas of low to high probability for the existence of unknown archaeological sites.
- 5-8-2 Reconnaissance Survey** - A Reconnaissance Survey (detailed field examination) shall be conducted where the Assessment Survey indicates that an archaeological site exists or is likely to exist. A reconnaissance survey is a detailed field examination designed to locate all prehistoric and historic archaeological resources within the project area.
- 5-8-3 Intensive Survey** - An Intensive Survey shall be conducted where evidence of an archaeological site has been found through the Reconnaissance Survey. An intensive survey represents an in-depth archaeological field examination of a particular archaeological site(s) for the express purpose of recovering sufficient information to enable an evaluation of the context, integrity and significance of the site.
- 5-9 FINAL RECORD SUBDIVISION PLAN** – Final Record Subdivision Plans shall conform to the Subdivision Improvement Plan, including any conditions specified by the Commission. A Detailed Final Plan shall consist of and be prepared in accordance with the following:
- 5-9-1 Drafting Standards** - The subdivision maps shall be produced by one of the following processes: Wash-off photographic polyester film, fixed line photographic polyester film, original ink drawing on polyester film or linen, or any other material approved by the public records administrator. This process shall be certified by a live stamp applied by the producer. The stamp shall be affixed with indelible red ink. The stamp shall include the name of the producer and the process used. It shall measure 1” by 2”. Original ink drawing will be so identified using the same process. The subdivision maps shall be thirty-six (36) inches long and twenty-four (24) inches wide or eighteen (18) inches long and twelve (12) inches wide at a scale approved by the Commission which shall have a scale no greater than one hundred (100) feet to the inch. The index sheet or first sheet shall contain a block to fill in all pages, dates, and revisions by page. The plan shall incorporate a survey of the parcel in accordance with the standards established by the Regulations of Connecticut State Agencies, Section 20-300b

through 20-300b-20 inclusive which shall be tied to the Connecticut State Plane Coordinate System by a closed traverse if land is within a distance to base control of 1,000 feet. The minimum size for all plan lettering shall be 80 guide "Leroy" or 3/32 inch. The original Subdivision Improvements Plan as revised shall be submitted upon approval of the subdivision. An additional two (2) copies shall be scaled in accordance with the pertinent tax map on file in the Assessor's office.

SECTION 6 – SITE DESIGN STANDARDS

6-1 PURPOSES AND APPLICABILITY

6-1-1 Purpose – In order to provide for streets of suitable location, width, and improvement to accommodate prospective traffic and afford satisfactory access to police, fire fighting, snow removal, sanitation, and road maintenance equipment, and to ensure the orderly growth and development of the Town of East Lyme, to provide meaningful open space and the protection of significant natural and community resources, and to promote the public health and welfare, it is the purpose of this section to provide more flexible standards intended to direct development to the land most suitable for development, produce more attractive, creative and efficient use of land, and for the following specified purposes:

1. To conserve open land, including those areas containing unique and sensitive natural features such as woodlands, steep slopes, streams, floodplains and wetlands, by setting them aside from development;
2. To provide greater design flexibility and efficiency in the siting of services and infrastructure, including the opportunity to reduce length of roads, utility runs, and the amount of paving required for residential development;
3. To reduce erosion and sedimentation by the retention of existing vegetation, and the minimization of development on steep slopes;
4. To provide for a diversity of lot sizes, building densities, and housing choices to accommodate a variety of age and income groups, and residential preferences, so that the community's population diversity may be maintained;
5. To implement adopted municipal policies to conserve a variety of irreplaceable and environmentally sensitive resource lands as set forth in the Town of East Lyme's Open Space Plan, including provisions for reasonable incentives to create a greenway system for the benefit of present and future residents;
6. To implement adopted land use, transportation, and community policies, as identified in the Town of East Lyme's Comprehensive Plan;
7. To protect areas of the Town of East Lyme with productive agricultural soils for continued or future agricultural use, by conserving blocks of land large enough to allow for efficient farm operations;
8. To create neighborhoods with direct visual access to open land, with amenities in the form of neighborhood open space, and with a strong neighborhood identity;

9. To provide for the conservation and maintenance of open land within the Town of East Lyme to achieve the above-mentioned goals and for active or passive recreational use by residents;
10. To provide multiple options for landowners in order to minimize impacts on environmental resources (sensitive lands such as wetlands, floodplain, and steep slopes) and disturbance of natural or cultural features (such as mature woodlands, hedgerows and tree lines, critical wildlife habitats, historic buildings and sites, and fieldstone walls);
11. To provide standards reflecting the varying circumstances and interests of individual landowners, and the individual characteristics of their properties;
12. To conserve scenic views and elements of the Town of East Lyme's rural character, and to minimize perceived density, by minimizing views of new development from existing roads; and
13. To preserve existing lot yields consistent with conventional subdivisions so as not to affect value.

As such, the provisions of this Section shall apply to all subdivisions of land within the Town of East Lyme and are hereby required.

6-1-2 Contextual Priorities - All subdivisions and land developments shall avoid or minimize adverse impacts on the Town of East Lyme's natural, cultural and historic resources, as defined below. As a guideline, the design of Buildable Land should be in a manner consistent with the following:

(A) Groundwater Resources - This section is intended to ensure that the Town's groundwater resources are protected for purposes of providing public water for its residents and businesses, and to protect the base flow of the Town's surface waters. These regulations shall be applied in conjunction with those provided for in Section 6-8 of these regulations, dealing with stormwater management, groundwater conservation and recharge.

The proposed subdivision and land development of any tract shall be designed to cause the least practicable disturbance to natural infiltration and percolation of precipitation to the groundwater table. (Through careful planning of vegetation and land disturbance activities, and the placement of streets, buildings and other impervious surfaces in locations other than those identified on the Existing Resources and Site Analysis Plan as having the greatest permeability where precipitation is most likely to infiltrate and recharge the groundwater.)

(B) Agricultural Land and Prime Agricultural Soils - Site design should avoid division of agricultural land and should minimize negative impacts on agriculture on and adjacent to the parcel. Structure and driveway

locations should be located so as to be clustered at the edges of open fields, away from areas of existing agricultural activity on or adjacent to the parcel. Vegetated areas should be preserved where they buffer agricultural operations.

- (C) **Ridge Lines and Scenic Roads** - Development near prominent hilltops and ridge lines should be sited so that building silhouettes will be below the ridge line as viewed from nearby streets. Clear-cutting of lots along ridgelines should be minimized. In considering the visual impact of development, the Commission may require additional reasonable restrictions to minimize the visibility of developments from existing public streets. Structures should be located to avoid prominent placement in the foreground of the viewshed. Subdivisions within view of national, state or locally-designated scenic roads shall be of particular concern relative to these standards.
- (D) **Natural Diversity Habitat Areas** - Lots should be configured and structures located so as to minimize disturbance and provide reasonable protection for natural habitats and communities as described in the Site Resource Assessment.
- (E) **Historic and Archaeological Resources** - Historic and prehistoric structures, sites and features shall be protected. Subdivisions and re-subdivisions shall be laid out to preserve all significant natural, cultural, historical and archaeological features identified on the Natural and Cultural Resource Map required in Section 4-2-3(A), or as determined by the Commission from expert testimony to be of significant natural, cultural or historical value.
 - i. Natural Resources are generally defined as environmentally valuable areas such as wetlands, watercourses, flood plains, areas of steep slopes, habitats, etc. Farmlands and forestlands are also to be considered as natural resources.
 - ii. Cultural Resources tend to be more subjectively defined. They include such things as vistas, scenic ridges, scenic roads, old houses, old stone walls, roads bounded by old stone walls, archeological sites, sites of historic interest, areas of traditional recreational value, animal pens, mill and factory sites, graves and/or burial grounds, water or shore access, etc.
 - iii. Archaeological Resources are areas of historic, prehistoric or symbolic importance, upon which occurred important historic or pre-historic events, or which are importantly associated with historic or pre-historic events or persons, or cultures, or which were subject to sustained historic or prehistoric activity of man. Historic Property

means any individual building, structure, object or site that is significant in the history, architecture, archaeology and culture of the state, its political subdivisions or the nation and the real property used in connection therewith.

- iv. Historic Structures and Sites - Plans shall be designed to protect existing historic resources of all types and encourage the protection, enhancement, and use of buildings and structures and appurtenant vistas having historic and/or aesthetic value which represent or reflect elements of the Town's cultural, social, economic and architectural history. The protection of an existing historic resource shall include the conservation of the landscape immediately associated with and significant to that resource, to preserve its historic context. Where, in the opinion of the Commission, a plan would have an impact upon an historic resource, the developer shall mitigate that impact to the satisfaction of the Commission by modifying the design, relocating proposed lot lines, providing landscape buffers, or other approved means.

Existing natural and cultural features that would add value to residential development or to the Town of East Lyme as a whole shall be preserved in the design of the subdivision. No trees or stone walls shall be removed from any proposed subdivision, nor any change of grade of the land affected, until approval of the subdivision has been granted. All trees on the plan required to be retained shall be preserved, and all trees, where required, shall be welled and protected against change of grade. If the parcel to be subdivided is found to contain an archaeological site(s), the Commission shall seek to maximize protection and in situ preservation of archaeological resources. The Commission may withhold approval of the plan unless the applicant:

- a. Restricts the full extent of the archaeological site, so as to preserve the same area free from development, by means of a permanent preservation easement granted to the Town or a recognized conservation entity, with perpetual rights to conduct limited archaeological research on the same area at reasonable times; or
- b. Upon recommendation by the Connecticut Historic Preservation Office and the State Archaeologist, the applicant has agreed to develop and implement a Data Recovery Program prior to construction, consisting of the professional documentation of the archaeological site by means of its physical destruction through archaeological excavation and removal. All costs associated with the Data Recovery Program shall be borne by the applicant.

- (F) **Historic Rural Road Corridors and Scenic Viewsheds** - The Town of East Lyme's Plan of Conservation and Development identifies a number of historic rural roads in various parts of the Town of East Lyme. All applications for subdivision and land development shall attempt to preserve the scenic visual corridors along such roads by incorporating them into Greenway areas or otherwise providing for building setbacks and architectural designs to minimize their intrusion. In instances where such designs fail to satisfactorily protect corridors, applicants will be required to provide naturalistic landscape buffers to minimize their adverse visual impacts. The species specified for such buffers shall be selected on the basis of an inventory of tree and shrub species found in existing hedgerows and along wooded roadside edges in the vicinity of the development proposal.
- (G) **Stone Walls** - Subdivisions should be designed to preserve all existing stone walls. Portions removed shall be rebuilt elsewhere on the property, or used to enhance other existing walls on the property. Stone walls fronting any existing public or private street shall be maintained intact. Stone walls or other natural and manmade features should be used for lot boundary lines and proposed street right-of-way delineation.
- (H) **Wetlands and Watercourses** - In order to protect water quality and wildlife habitats, development and disturbance should be minimized within 100 feet of any wetland and of any watercourse as required by the East Lyme Inland Wetlands and Watercourses Regulations. These provisions do not require the creation of an undisturbed buffer around any wetland or watercourse.
- (I) **Stream Valleys, Swales, Springs and Other Lowland Areas** - Stream valleys (which include stream channels and floodplains), swales, springs and other lowland areas are resources that warrant restrictive land use controls because of flooding hazards to human life and property, their ground water recharge functions, their importance to water quality and the health of aquatic communities, and their wildlife habitats. They are generally poorly suited for on-site subsurface sewage disposal systems. The following activities shall be minimized:
- i. Disturbance to streams and drainage swales; and
 - ii. Disturbance to year-round wetlands, areas with seasonally high water tables, and areas of surface water concentration.
- (J) **Trails** - The integrity of existing cart paths, historic ways, discontinued and abandoned roads, and trails, which can serve as connections to conservation open space lands or adjacent parcels should be preserved.

1. When a subdivision or land development proposal is traversed by or abuts an existing trail customarily used by pedestrians and/or equestrians, the Planning Commission may require the applicant to make provisions for continued recreational use of the trail;
2. The applicant may alter the course of the trail within the tract for which development is proposed under the following conditions:
 - a. The points at which the trail enters and exits the tract remain unchanged;
 - b. The proposed alteration exhibits quality trail design according to generally accepted principles of landscape architecture (For example: Bureau of State Parks publication Non-Motorized Trails); and
 - c. The proposed alteration does not coincide with a paved road intended for use by motorized vehicles.
3. When trails are intended for public or private use, they shall be protected by a permanent conservation easement on the properties on which they are located. The width of the protected area in which the trail is located should be a minimum of ten feet. The language of the conservation easement shall be to the satisfaction of the Planning Commission upon recommendation of the Town Attorney;
4. The land area permanently designated for trails for public use may be credited toward the open space requirement described in Section 23 of the Zoning Regulations;
5. An applicant may propose and develop a new trail. If said trail is available for use by the general public and connects with an existing trail, the land area protected for said trail may be credited toward the open space requirement described in Section 23 of the Zoning Regulations;
6. Trail improvements shall demonstrate adherence to principles of quality trail design;
7. Trails shall have a vertical clearance of no less than ten (10) feet;
8. Width of the trail surface may vary depending upon type of use to be accommodated, but in no case shall be less than three (3) feet or greater than six (6) feet;
9. No trail shall be designed with the intent to accommodate motorized vehicles.

- (K) **Trees** - Subdivisions should be designed to preserve healthy mature woodlands, specimen trees and groups of trees that significantly contribute to the aesthetic or natural character of the site and adjacent streets, including trees over 18 - inches d.b.h (diameter at breast height), woodlands and vegetated buffers along roadways, property lines, watercourses, and stone walls as buffers between adjacent properties and streets.
- (L) **Woodlands** - All woodlands on any tract proposed for subdivision or land development shall be evaluated by the applicant to determine the extent to which such woodlands should be designated partly or entirely as Conservation Land or Development lands. Evaluation criteria shall include:
- i. Configuration and size;
 - ii. Present conditions, i.e., stocking, health and species composition;
 - iii. Site potential, i.e., the site's capabilities to support woodlands, based upon its topographic, soil and hydrologic characteristics;
 - iv. Ecological functions: i.e., in protecting steep slopes, erodible soils, maintaining stream quality and providing for wildlife habitats; and
 - v. Relationship to woodlands on adjoining and nearby properties and the potential for maintaining continuous woodland areas.

The evaluation of the tract's woodlands shall be undertaken by a forester, landscape architect, horticulturist or another qualified professional acceptable to the Planning Commission. This evaluation shall be submitted as a report and made a part of the application for a preliminary plan. At a minimum, that report shall include one or more maps indicating boundaries and conditions of woodland areas accompanied by a report addressing the above criteria.

In designing a subdivision and land development plan for any tract of land, the applicant shall be guided by the following standards:

- a. Healthy woodlands exceeding one acre shall be preserved and designated as Greenway areas, to the maximum extent possible. Proposed site improvements shall be located, designed and constructed to minimize the loss or degradation of woodland areas;
- b. Subdivisions shall be designed to preserve woodlands along roadways, property lines and lines occurring within a site such as streams, swales, stone walls, fences and hedgerows. Such lines and the native vegetation associated with them shall be preserved as

buffers between adjacent properties and between areas being subdivided within a property. Preservation shall include ground, shrub, understory and canopy vegetation.

- c. Disturbance or removal of woodlands occupying environmentally sensitive areas shall be undertaken only when approved by the Planning Commission and on a limited, selective basis to minimize the adverse impacts of such actions. This shall include but not necessarily be limited to vegetation performing important soil stabilizing functions on wet soils, stream banks, and sloping lands.
- d. No clearing or earth disturbance (except for soil analysis for proposed sewage disposal systems) shall be permitted on a site before the completion of subdivision and land development agreements. The determination of sight distance clearances along roadways shall be made graphically and not by clearing on-site prior to final plan approval.

(M) Slopes - Moderately sloping lands (15 to 25-percent) and steep sloping lands (over 25-percent) are prone to severe erosion if disturbed. Erosion and the resulting overland flow of soil sediments into streams, ponds and public roads, are detrimental to water quality and aquatic life, and a potential hazard to public safety.

- i. Areas of steep slope shall be preserved to the maximum extent possible.
- ii. All grading and earthmoving on slopes exceeding 15-percent shall be minimized. On slopes of 15 to 25-percent, the only permitted grading beyond the terms described above, shall be in conjunction with the siting of a single family dwelling, its access driveway and the septic system, which should typically be designed with a long, narrow drainage field following the land contours.
- iii. No site disturbance shall be allowed on slopes exceeding 25-percent except grading for a portion of a driveway accessing a single family dwelling when it can be demonstrated that no other routing, which avoids slopes exceeding 25-percent is feasible.
- iv. Grading or earthmoving on all sloping lands of 15-percent or greater shall not result in earth cuts or fills whose highest vertical dimension exceeds six feet, except where in the judgment of the Planning Commission no reasonable alternatives exist for construction of roads, drainage structures and other public improvements, in which case such vertical dimensions shall not exceed 12-feet. Roads and driveways shall follow the line of existing topography to minimize

the required cut and fill. Finished slopes of all cuts and fills shall be as required to minimize disturbance of natural grades.

- (N) **Significant Natural Areas and Features** - Natural areas containing rare or endangered plants and animals, as well as other features of natural significance, exist throughout the Town of East Lyme. Subdivision applicants shall take all reasonable measures to protect significant natural areas and features either identified by the Town of East Lyme's Plan of Conservation and Development or by the applicant's Natural and Cultural Resources and Site Analysis Plan (as required in Section 4-2-3(A)) by incorporating them into proposed open space corridors or avoiding their disturbance in areas proposed for development.
- (O) **Streets, Roadways, Sidewalks, and Driveways** - Streets, sidewalks, driveways and utility corridors should adapt to existing contours, terrain, wetlands, watercourses, and other linear site features such as stone walls, significant tree lines, and the pattern of open fields in order to minimize disturbance of existing features, to minimize required cuts and fills and the potential for erosion and to retain the rural characteristics of the subdivision site. Streets, sidewalks, driveways and utility corridors shall use or share existing accesses and rights-of-way where feasible; follow existing contours to achieve angled ascents where practicable, and avoid areas of very steep slopes.

6-1-3 Site Design Process - Proposals for all residential subdivisions shall follow a design process as described below.

- (A) **Lot Yield** - Describe how to determine yield using standard zoning and subdivision regulations.
- (B) **Potential Density Increase** - The Commission may approve one or more of the following potential density increases in Section 6-1-4 below for any residential development, provided at least one of the following conditions are met:
 - i. For developments within the RU-40 Zone District utilizing individual septic where more than 30-percent of the parcel is permanently preserved as open space;
 - ii. For developments within the RU-80 and RU-120 Zone Districts utilizing individual septic where more than 50-percent of the parcel is permanently preserved as open space; and
 - iii. A substantial open space buffer is permanently preserved as open space along the undeveloped portions of collector or arterial roads and the buffer is:

- at least 200-feet in width and is significantly uninterrupted in length unless waived by the Commission in accord with Section 23.5(B)2 of the East Lyme Zoning Regulations,
- not included in the calculation of any lot area, and
- retained in its natural state except for a public, private or common roadway accessing development on the interior of the parcel.

OR;

iv. The development promotes housing opportunities, consistent with soil types, terrain, and infrastructure capacity and promotes housing choice and economic diversity to help meet housing needs.

(C) **Building Site Locations** - Building site locations shall be identified within the designated buildable land. Buildings shall be constructed in the location shown on the Final Approved Plan.

(D) **Street Location** - With building site locations identified, Applicants shall delineate a street or driveway system to provide vehicular access to each lot in a manner conforming to the tract's natural topography and providing for a safe pattern of circulation, ingress and egress to and from the building lots and the subdivision. Streets shall minimize adverse impacts on existing open space land.

(E) **Lot Line Location** - Where practicable lot lines should follow the configuration of building sites and streets in a logical and flexible manner. Otherwise, the design of the lots and location of streets should be consistent with the existing topography and landscape. Lot lines should follow existing natural and man-made boundaries such as stone walls, tree lines and patterns of open fields. All proposed lots shall show the location of the proposed principal building, driveway, sewerage leaching fields (primary and reserve), and well.

6-1-4 Density Increases - The Commission may increase the maximum residential density allowed in a development provided:

(A) The density increase shall not exceed one-half-percent (.50%) for each additional percentage that open space is preserved in excess of the minimum open space requirement provided by the Zoning Regulations. *(e.g. if 50% of the parcel is preserved as open space, this is 20% greater than the minimum requirement of 30% and the Commission may increase the density by up to 10%.)*

- (B) The density increase shall not exceed ten-percent (10%) in the number of units provided in a residential development to the extent that Housing Affordability Units (Housing that may be purchased or rented by households earning no more than eighty-percent (80%) of the areas median household income, as determined and reported by the U.S. Department of Housing and Urban Development, and using no more than thirty-percent (30%) of their annual income housing costs) are developed (*e.g. if 10% of the proposed housing units will be deed restricted as Housing Affordability Units, the Commission may increase the density by up to 10%*).

Prior to modifying any such requirement, the Commission shall make a finding on the record that proper provisions have been made for water supply, sewage disposal, control of wastes, and the protection of water quality.

6-2 LOT DESIGN SPECIFICATIONS – Lots shall be laid out in a manner generally consistent with specifications of this section.

6-2-1 Lot Size and Configuration - The size of the lots shall be as required by the Zoning Regulations. Corner lots shall be of sufficient dimensions so that any structure placed thereon shall conform to the front building setback line on each street. Where practicable lot lines should follow the configuration of building sites and streets in a logical and flexible manner. Otherwise, the design of the lots and location of streets should be consistent with the existing topography and landscape. Lot lines should follow existing natural and man-made boundaries such as stone walls, tree lines and patterns of open fields. There shall not be any fragments of a lot or remainder of a subdivision area. No lot shall be created, regardless of size, which is rendered useless for building due to utility easement, rights-of-way, wetlands, watercourses, or topography. Such property shall be combined with adjacent lots or Conservation Land. The building setback lines shall conform to the requirements of the Zoning Regulations. Interior (Back Lots or Rear Lots) Lots, herein defined as lots with an access strip that provides road frontage and being primarily positioned behind another lot with adjacent frontage on the same road shall be permissible provide adequate access is provided.

6-2-2 Health Requirements – Unless systems are located in common Conservation Land, in areas specifically designated by the Commission for this purpose, each lot shall have sufficient area to accommodate, where public facilities are not otherwise provided, a private water supply and a private subsurface sewage disposal system and reserve area.

6-2-3 Unbuildable Lot - No lot shall be approved if found unsuitable for occupancy and building by reason of utility easements, unstable or adverse soil conditions,

topography, water or flooding conditions, and/or public health concerns related to water supply and/or wastewater disposal; such lots shall be combined with another adjacent lot or Conservation Land.

6-2-4 Building Locations – The orientation of individual building sites should be such as to maintain maximum natural topography and cover. Structures should be oriented in a rational and pleasing manner in relation to existing and proposed public and private streets. Buildings should be spaced and set back an approximately uniform distance from an existing or proposed public street or private road. Where site conditions, topography, configuration of existing lots, roads, structures, rights-of-way, legal requirements, or other constraints preclude full compliance with this Section, Applicants shall consult with the Town Planner to determine recommended priorities and potential site design alternatives. Where practicable, the Commission may alter the configuration and location of Conservation Land, Buildable Land, streets, lots, lot lines, and building sites for the purposes of better achieving the goals and objectives of these Regulations and the East Lyme Plan of Conservation and Development.

6-2-5 Lot Access - Notwithstanding that all lots shall meet the suitability requirements of this section, actual access to two (2) adjacent lots may be provided by a combined access drive. The Commission may permit more than two (2) lots to be served by a single access drive if it finds that no traffic hazard will result. If the proposed access will serve more than three (3) lots, then the access shall conform to the requirements of a private street.

- (A) All driveways shall be located, designed and constructed in a manner, which prevents erosion and minimizes driveway drainage onto existing or proposed streets and/or abutting properties and structural drainage facilities shall be incorporated into the driveway design and construction, as necessary, to prevent excessive drainage onto streets or abutting properties.
- (B) No driveway shall be greater than 15% slope at any point. Any driveway having a grade of 10% or more, but not exceeding 15%, shall be paved for the entire length of the driveway. Shared driveways shall not exceed 10% or more on the shared portion of driveway.
- (C) All driveways shall have a minimum width of ten (10) feet.
- (D) All driveways shall be paved with bituminous concrete from the edge of the street pavement to the edge of the street right-of-way. The Commission may require additional paving based on the location, environmental or geological concerns.

- (E) The Commission may determine that a minimum of one (1) turn-around, 20' by 20', will be required if the length of the driveway exceeds 300 feet, or if the surrounding terrain will pose a safety problem. The Commission may also, if it chooses, direct that the Town Engineer or Town Planner make such a determination as to the need for, and location of, any additional turn-around.
- (F) All plans for subdivision and re-subdivision which show common driveways shall clearly state which lots are sharing the driveways. The Commission shall require a note to be placed on the plan stating that the deed(s) are to include all information regarding easements, rights and responsibilities regarding the common driveway. All proposed easements shall be shown on the plan with meets and bounds.

6-2-6 Energy Efficiency and Conservation

- (A) The applicant shall demonstrate to the Commission that in developing the subdivision plan, the use of passive solar energy techniques which would not significantly increase the cost of the housing to the buyer, after any available tax credits, subsidies, and exemptions, has been considered. Such techniques shall maximize solar heat gain, minimize heat loss, and provide natural ventilation during the cooling season. The site design techniques shall include, but not be limited to: (1) house orientation; (2) street and lot layout; (3) vegetation; (4) natural and manmade topographical features; and (5) protection of solar access within the development. A written statement outlining how this requirement has been adhered to shall be required.
- (B) All subdivisions shall be planned and designed to encourage energy efficient development patterns and the use of renewable energy forms through the use of as many of the following guidelines as possible:
 - (1) Where natural features or other planning considerations do not limit street layout and location, streets should have an east-west orientation to the greatest extent possible with acceptable variations up to 15 degrees north or south of due east to provide for southerly building orientation.
 - (2) Lot lines may be oriented in a fashion other than that provided in Section 6-2-1 of these Regulations if such orientation is necessary to secure, protect, or control solar access.
 - (3) Primary and reserve leaching field areas should be planned and located to the south of a proposed building location whenever such location is suitable for such purposes and will aid in the use of solar energy

systems due to tree removal and re-grading associated with the sewage disposal system.

- (4) Existing vegetation and natural terrain located to the north of any proposed structure which serves as a wind barrier should remain intact. Other methods of providing for manmade wind barriers, such as earth mounds, should be encouraged, as appropriate.
- (5) The location and designation of open spaces, parks and playgrounds, should take into account the energy requirements, particularly for solar and wind access, of the subdivision as follows:
 - (a) If the maximum possible number of lots have good solar or wind access, land reserved for open space should be located so as to avoid the creation of lots without good solar or wind access; or
 - (b) If the land is such that few lots can be provided with good solar access, land for open space should be located on land which has good solar or wind access in order to provide for future use of community energy systems.
- (6) The designation and reservation of land for open space, parks, playgrounds, or their public uses should not preclude its use in meeting community energy requirements. Such areas may be used to locate facilities, subject to any other applicable requirements of these Regulations and Town Zoning Regulations.
- (7) Species of street trees should be chosen taking into account their suitability in relationship with solar access objectives. Street trees should be located in such a manner as to avoid shading the most southerly side of proposed structures in order to facilitate the use of solar energy systems.

6-3 ADDITIONAL NON-RESIDENTIAL SUBDIVISIONS DESIGN STANDARDS - In addition to the requirements and standards in these Regulations, which are appropriate to the planning of all subdivisions, the applicant shall demonstrate to the satisfaction of the Commission that the street, parcel, and block pattern proposed is specifically adapted to the uses anticipated and takes into account other uses in the vicinity. The following requirements and standards shall be met:

- (A)** Proposed industrial lots shall be suitable in area and dimension to accommodate the types of industrial development anticipated.
- (B)** Street rights-of-way and pavement shall be adequate to accommodate the type and volume of traffic anticipated to be generated thereupon.
- (C)** Special requirements may be imposed by the Planning Commission with respect to the street, curb gutter, and sidewalk design and construction.

- (D) Special requirements may be imposed by the Planning Commission with respect to the installation of public utilities, including water, sewer, and stormwater drainage.
 - (E) Every effort shall be made to protect adjacent residential areas from potential external impacts from a proposed commercial or industrial subdivision, including the provision of extra depth in parcels backing up on existing or potential residential development and provisions for a permanently landscaped buffer strip when necessary.
 - (F) Streets carrying nonresidential traffic, especially truck traffic, shall normally not be extended to the boundaries of adjacent existing or potential residential areas.
- 6-4 **GENERAL IMPROVEMENTS** – Subdivisions including related streets, drainage, and other improvements required by these Regulations, shall be planned, designed, and constructed in accordance with the standards hereinafter specified.
 - 6-5 **PLAN OF CONSERVATION AND DEVELOPMENT** – Subdivisions shall be planned and designed in general conformity with the East Lyme Plan of Conservation and Development and the Ordinance Concerning Flood Damage Prevention.
 - 6-6 **SUBDIVISION NAME** – The proposed name of the subdivision shall not duplicate, or too closely approximate phonetically, the name of any other subdivision in the town.
 - 6-7 **OPEN SPACES** – The Commission shall require that land be reserved for open space in accordance with Section 7 of these Regulations.
 - 6-8 **STORMWATER MANAGEMENT** – It is recommended that all applicants meet with the Town Engineer prior to any East Lyme applications that are subject to review by these regulations and standards (e.g. wetlands). Stormwater management systems shall be designed to manage site runoff to minimize or eliminate surface and groundwater pollution, prevent flooding, control peak discharges and provide pollutant renovation. Design of a stormwater management system shall be in accordance with the Connecticut Department of Transportation Drainage Manual and the Connecticut Department of Environmental Protection Stormwater Quality Manual, as amended. This section, (6-8) shall prevail when conflicts arise between this document and other reference documents. Additionally, all designs shall meet the following specific criteria as amended:

6-8-1 General Requirements

- (A) The applicant shall be fully responsible for constructing adequate facilities for the control, collection, conveyance and acceptable disposal of stormwater, other surface water and subsurface water, whether originating within the subdivision area or in a tributary drainage area. All drainage facilities shall be designed by an Engineer licensed as a professional engineer in the State of Connecticut and shall be subject to the approval and final acceptance of the Town Engineer.

- (B) The storm drainage system shall be separate and independent of the sanitary sewer system.
- (C) When a proposed drainage system will carry water across private land outside the subdivision, appropriate drainage easements must be secured and indicated on the map.
- (D) When the applicant proposes to connect the storm sewer to an existing storm sewer, calculations must be submitted to demonstrate the adequacy of the existing sewer to accept the added flow.
- (E) Stormwater shall not be permitted to cross the surface of any street but must be piped underground. Catch basins shall be located on both sides of the street on continuous grades, at all sags in the roadway, and near the corners of the roadway at intersecting streets.
- (F) If in the judgment of the Commission the runoff from the subdivision will adversely affect the receiving stream or natural waterway, other means of runoff water disposal shall be required.
- (G) Proper connections shall be made with any existing public drainage system capable of handling the increased runoff, within 400 feet of the subdivision, at the applicant's expense as may be appropriate.
- (H) Where adjacent property is not subdivided and no public stormwater conveyance system is within 400 feet, provisions may be required by the Commission for extension of the system by continuing appropriate conveyance structures to the higher exterior boundaries of the subdivision, at such size and grade as will allow for their proper functioning.
- (I) No unnatural depressions shall be allowed on lots, rights-of-way or recreation and open space area unless properly drained or approved under the Storm Water Management Plan.
- (J) The proposed drainage facilities shall be designed in accordance with any town drainage plan and with due regard for the ultimate development within the drainage basin.
- (K) Any work to be performed on streams or within a designated inland wetland area must be approved by the Inland Wetlands Agency of East Lyme and any proposed work within the tidal wetlands must be approved by the State Department of Environmental Protection. Work in both tidal and inland wetlands located within the coastal boundary must be consistent with the policies of the Connecticut Coastal Management Act. Work in both inland and tidal wetlands may also require a permit from the U.S. Army Corps of Engineers.

- (L) Prior to the Town accepting the streets in any new subdivision, the applicant must convey by plans and deeds the rights-of-way for the streets and easements for all drainage facilities within the Town road system and in other areas the Commission deems necessary.
- (M) Structures constructed as part of the Stormwater Management System shall not be placed within the area designated as open space.

6-8-2 Peak Flow and Volume Control - The peak flow rates and stormwater volumes shall be calculated for both pre- and post-construction conditions using the most appropriate of the United States Department of Agriculture, Soil Conservation Service, Technical Release (TR) and Army Corps of Engineering, Hydrologic Engineering Center (HEC) series or other hydraulic programs approved by the Town Engineer. The standard for characterizing pre-development land use for on-site areas shall be woods in good condition unless otherwise approved by the Town Engineer. The calculation shall assume full build-out of the subdivision using theoretical yields unless land is set aside as buffer areas and protected in perpetuity through a conservation easement.

- (A) There shall be no increase in peak rate of run-off leaving the site calculated for pre-construction and post-construction site conditions using the 24-hour rainfall amount for storm frequencies of 2, 5, 10, 25, 50, and 100 years for each sub-catchment drainage area. The volume retained to mitigate the pre-construction to post-construction increase in peak rate of runoff can be released at a rate not to exceed the pre-construction peak rate by a method approved by the Town Engineer.
- (B) The calculated volume increase from pre-construction to post-construction calculated using the 24-hour rainfall amount for storm frequencies of 2, 5, 10, 25, 50, and 100 years for each subcatchment drainage area shall be retained on site and infiltrated or released by a method to be approved by the Town Engineer.

6-8-3 Groundwater Recharge Volume (GRV) – The groundwater recharge volume is the volume of stormwater that shall be captured and infiltrated for each storm. The GRV shall be calculated as described in Sect. 7.5.1 of the DEP Stormwater Manual. The size of the infiltration basin shall be calculated using the formula and infiltration rates as specified for infiltration basins herein. The GRV requirement may be met if the WQV is infiltrated.

6-8-4 Water Quality Volume (WQV) - The Water Quality Volume (WQV) shall be calculated as described in Section 7.4.1 of the DEP Stormwater Manual. The WQV shall be retained on-site in an off-line structure and treated by either infiltration or filtration or a combination thereof for each sub-drainage area of the site or as approved by the Town Engineer.

- (A) The WQV may be reduced by the following methods:
1. Decreasing the impervious area of the site using Low Impact Development design;
 2. Subtracting the area of land dedicated as Open Space in accordance with Section 10 of the East Lyme Subdivision Regulations from the total area of the site in the calculation of the WQV, provided the area is to remain in an undisturbed natural state in perpetuity and is protected during construction and does not discharge to downstream WQV treatment structures;
 3. Subtracting the GRV from the WQV if the GRV is infiltrated separately in each sub-basin from the WQV and there is equivalent treatment of pollutants;
 4. Subtracting the area of land from the WQV calculation that drains by overland sheet flow and then across a buffer strip prior to entering a wetland or adjacent property that meets all the following conditions:
 - a. The slope of the overland sheet flow is less than 15%.
 - b. The length of the overland flow upgradient of the buffer used in this calculation is limited to a maximum of 150 feet for pervious surfaces and 75 feet for impervious surfaces. The WQV from overland flow exceeding these limits must be intercepted and treated accordingly.
 - c. The buffer strip is a minimum of 50 feet wide.
 - d. The buffer strip remains undisturbed and is protected in perpetuity as open space, conservation easement or as approved by the Director of Planning.
 - e. The calculated run-off velocity across the buffer strip is less than 2 feet per second.
 - f. The average slope of the buffer strip is 6% or less.
- (B) Structures including swales, basins, bio-retention areas, rain gardens, and gravel based vegetated wet basins constructed to capture the WQV shall meet the following requirements:
1. Structures shall be designed with the WQV off-line unless approved by the Town Engineer.
 2. Basins shall be designed to drain within 12 to 72 hours.

3. Infiltration basins shall be constructed a minimum of 1.5' above the maximum ground water level and be located a minimum of 50' horizontally from a wetland. The maximum groundwater level is defined as the level to which groundwater rises for a duration of one month or longer during the wettest season of the year or as determined by the Town Engineer. For the purposes of these regulations the term "maximum ground water level" shall be synonymous with the term "groundwater table".
4. WQV structures must be designed with a suitable overflow and or outfall structure.

6-8-5 Requirements for Infiltration Basins/Areas

- (A) Infiltration basins shall be sized to drain within a 24-hour period using the following formula: $t_p = D/K$, where t_p is the ponding time in days, D is the depth of the basin in feet, and K is the infiltration rate in feet per day. The infiltration rates for each soil group shall be as follows:

<u>Soil Group</u>	<u>K (ft/day)</u>
A	0.6
B	0.3
C	0.1
D	0.0

Infiltration rates determined from field-testing using the ASTM D 3385 Standard Test Method for Infiltration Rate of Soils in Field Using Double-Ring Infiltrometer can be used in lieu of those listed above subject to a factor of safety of 2 (use 50 percent of the measured infiltration rate) to account for clogging over time.

- (B) Basins shall be protected from the accumulation of sediment and debris that adversely affect the infiltration rate of the basin (i.e. sediment forebays, plunge pools, or deep sump catch basins).
- (C) The areas proposed for infiltration shall be cordoned off during construction to protect these areas from compaction by construction equipment.
- (D) Basins shall be completely vegetated with plants tolerant to frequent inundation of water. Bare sand, gravel or stone surfaces are not allowed.
- (E) Infiltration basins shall be tested in situ after construction to ensure the design parameters are met. And, if design parameters are not met, the

area and/or depth shall be adjusted as necessary to meet design specifications.

- (F) Underdrains and/or curtain drains cannot be used to locally lower the elevation of the existing ground water table adjacent to the infiltration basin. Underdrains shall not be placed under infiltration basins.
- (G) Infiltration basins must be constructed on in-situ soils unless otherwise approved by the Town Engineer.
- (H) The bottom of an infiltration basin shall be a minimum of 1.5' above the maximum ground water level.
- (I) It is the applicant's responsibility to obtain all applicable permits. If directed by the Town Engineer, the applicant shall have the Connecticut Department of Environmental Protection Dam Safety Unit (DEP) review the plans to determine if dam construction permits are required for the construction of structures impounding water. The DEP's determination shall be submitted with the formal subdivision application to the Town Planning Department.

6-8-6 Requirements for Filtration Basins/Areas

- (A) Basins shall be protected from the accumulation of sediment and debris that adversely affect the filtration rate of the basin (i.e. sediment forebays, plunge pools, or deep sump catch basins).
- (B) Basins shall be completely vegetated with plants tolerant to frequent inundation of water. Bare sand, gravel or stone surfaces are not allowed.
- (C) Filtration basins shall be tested in situ after construction to ensure the design parameters are met. And, if design parameters are not met, the area and/or depth shall be adjusted as necessary to meet design specifications.
- (D) Underdrains and/or curtain drains cannot be used to locally lower the elevation of the existing ground water table adjacent to the filtration basin or structure.
- (E) It is the applicant's responsibility to obtain all applicable permits. If directed by the Town Engineer, the applicant shall have the Connecticut Department of Environmental Protection Dam Safety Unit review the plans to determine if dam construction permits are required for the construction of structures impounding water. The DEP's determination shall be submitted with the formal subdivision application to the Town Planning Department.

- (F) Underdrains may be used adjacent to filtration basins above the maximum ground water table. The discharge from the structures shall be considered in the calculation of flow and volume.
- (G) All structures shall be designed with an emergency spillway.

6-8-7 Exemptions

- (A) Subdivisions consisting of 3 lots or less may request waivers, in accordance with Section 4-13, of specific sections of 6-16 with the approval of the Planning Commission provided all of the following conditions are met:
 1. The applicant can demonstrate that the water quality of the receiving aquifer, wetland or watercourse is not adversely affected.
 2. The proposed development will not cause or exacerbate downstream flooding.

6-9 FLOODING REQUIREMENTS – Consistent with the East Lyme Ordinance concerning Flood Damage Prevention as amended June 6, 1984, land subject to flooding, as identified on the Federal Insurance Administration Flood Insurance Rate Map (FIRM) dated June 15, 1984, as revised, on file with the Town Clerk, shall not be subdivided unless the following conditions are met:

6-9-1 The Commission determines that the proposed subdivision is reasonably safe from flooding and when a subdivision is proposed in a special Flood Hazard Area, as shown on the Flood Insurance Rate Map (FIRM) dated June 15, 1984, as revised, it shall be reviewed to assure that:

- (A) All proposals are consistent with the need to minimize flood damage within the flood-prone area.
- (B) All public utilities and facilities, such as sewer, gas, electrical, and water systems are located and constructed to minimize or eliminate flood damage.
- (C) Adequate drainage is provided to reduce exposure to flood hazards.
- (D) New and replacement water supply systems are designed to minimize or eliminate infiltration of floodwaters into systems.
- (E) New and replacement sanitary sewer systems are designed to minimize or eliminate infiltration of floodwaters into the systems and discharges from the systems into floodwaters.
- (F) On-site disposal systems are located to avoid impairment of them or contamination from them during flooding.

(G) Base flood elevation data shall be provided for subdivision proposals and other proposed developments which contain at least 50 lots or six (6) acres (whichever is less).

6-9-2 Applicants for subdivisions within special Flood Hazard Areas shown on the town's Flood Insurance Rate Map (FIRM) dated June 15, 1984, as revised, will be required to submit with their applications a copy of those materials required under Section 4.1 and Section 5.4 (Floodways) of the town's Flood Damage Prevention Ordinance, as amended June 6, 1984, demonstrating that the flood-carrying capacity will be maintained with any altered or relocated portion of any watercourse.

6-9-3 The Planning Commission, in cooperation with the Building Official and Zoning Enforcement Official, shall notify, in riverine situations, adjacent communities, the Southeastern Connecticut Regional Planning Agency, and the Connecticut Department of Environmental Protection prior to approving any alteration or relocation of a watercourse, and submit copies of such notices to the Federal Insurance Administrator.

6-10 STREET AND ROADWAY DESIGN SPECIFICATIONS

6-10-1 Streets and Roadways - Proposed streets and rights-of-way shall be planned in such a manner as to provide safe and convenient access to proposed lots, with due consideration for accomplishing an attractive layout and development of the land in the subdivision and in the neighborhood. Streets should, in general, follow the contour of the land and shall have a location and grade which preserve the natural terrain, substantial trees, woods and other natural features in the subdivision and which enhance property values in the subdivision. Proposed local streets and rights-of-way shall be planned to discourage through traffic but also to provide a safe and convenient system for prospective traffic in the subdivision. Local streets shall also provide a safe and convenient system for present and prospective traffic in the neighborhood around the subdivision and shall be planned where appropriate to provide for continuation of existing streets in adjoining areas and for projection into adjoining properties when subdivided. Proposed streets shall be in harmony with existing or proposed streets as shown in the East Lyme Plan of Conservation and Development, especially with regard to safe intersections with such streets. Thoroughfares shall be planned where necessary to conform with the Town Plan of Conservation and Development and where necessary as a feeder street to a neighborhood. Proposed streets which may be projected into adjoining properties shall be carried to the boundary line; no reserve strips will be permitted. Proposed streets shall be designed and laid out so as to preserve important elements of natural or manmade topographical feature, including existing roadways and paths, old stone fences or walls, significant ledge areas, historical patterns of land use and to minimize impact on environmentally sensitive coastal or wetland areas.

6-10-2 The Design of Each Street shall reflect considerations of its function, vehicular and pedestrian safety, and its use by maintenance and emergency vehicles. No subdivision shall be approved unless the area to be subdivided shall have frontage on, and access from, an existing street that is suitably improved and paved and is shown upon a map approved by the Commission and recorded in the East Lyme Land Records. Such street, roadway, or driveway (including private or common driveways) must be suitably improved as required by the appropriate regulations and specifications, or be secured by a performance bond.

6-10-3 Private Streets or Roadways

- (A) The Commission may approve a proposed street, roadway as a permanent private street or roadway if the Commission finds that such street shall not carry more traffic than is expected of a Light Residential Street serving only abutting lots, that such street will not impair the orderly development of the neighborhood, that there will be safe and convenient circulation for vehicles and pedestrians, including emergency vehicles, and that there will be suitable arrangements for maintenance and repair.
- (B) Private Streets or Roadways approved under the East Lyme Subdivision Regulations shall adhere to all Town road design standards. The design speed of 25 miles per hour shall be used for all private roads. The following items may deviate from the Town standards using the American Association of State Highway and Transportation Officials (AASHTO) "**Guidelines for Geometric Design of Very Low-Volume Local Roads (ADT<400)**" 2001 (LVR Guidelines) as amended and AASHTO's "**A Policy on Geometric Design of Highways and Streets 2001**" (for ADT<=400) as amended:
- i. Road width of the paved portion of the road may be reduced to 18 feet;
 - ii. Private Streets or Roadways must demonstrate that the proposed street(s) meets the design requirements for Very Low-Volume Roads ADT < 400 as set forth in the "LVR Guidelines" and the "Policy on Geometric Design of Highways and Streets 2001" as amended and shall not exceed 400 ADT, now or in the future, using ten (10) ADT per household. The Proximity of lots to multiple entrances will need to be considered in determining ADT. Any subdivision proposing over 40 building lots shall require a traffic study with a trip generation and impact analysis demonstrating the private streets will not exceed 400 ADT;

- iii. The "LVR Guidelines" for guiderail placement may be utilized. The Planning Commission and/or Town Engineer may require guiderail in locations that are deemed necessary;
 - iv. Curb may be eliminated if the shoulders slope away from the road and adequate roadside drainage is proposed and properly designed to handle a 25 year storm event (Minimum cover over water lines must be maintained when crossing swales);
 - v. Catch basins may be eliminated if no adjacent curb is proposed and the requirements of item "iv" are met;
 - vi. Underdrain may be eliminated if proposed drainage swales are deep enough to intercept ground water and prevent ground water from reaching the base and sub-base of the proposed road;
 - vii. Shallow drainage swales may be proposed when underdrain is installed below to satisfy the requirements for underdrain and item "iv";
 - viii. Super-elevation may be proposed when the shoulder on the uphill side of the private road slopes away from the road to provide drainage for snow melt (see number items iv, vi and vii);
 - ix. The shoulder width shall be a minimum of 2 feet. Sightline for driveways on private roads shall be designed in accordance with the "LVR Guidelines" using a 25 mph design speed;
 - x. HDPE pipe may be used outside of the Town Right-of-Way (ROW) in the private road ROW. (Minimum diameter allowed is 15 inches).
- (C) The subdivision plans shall show the proposed street clearly labeled "Private Street".
- (D) The subdivision plans shall contain a note, approved by the Commission, which clearly states, "This Private Street will not be owned by the Town of East Lyme. All maintenance, repair, and services such as snow removal, sanding, and sweeping of the streets will be the responsibility of the abutting landowners."

- (E) The subdivision plans shall contain a note approved by the Commission which clearly states, "The Town of East Lyme shall not be responsible for the initial cost, maintenance fees, or utility bills associated with all street sign or street lights located on a private road or adjacent to and serving a private road."
- (F) The subdivision plans shall contain notes, approved by the Commission, which are intended to inform the purchasers of lots that certain public services may be restricted from the private street. Services such as refuse and recycling pickup, school bus access and postal delivery may be identified, based on the scope of services offered and public policies in effect at the time of approval.
- (G) The Record Subdivision Plan shall contain the notes required by Section 6-10-3 (D) and (E). The deeds for each proposed lot shall provide language, intended to inform the purchasers of lots, which clearly states, "this Private Street will not be owned by the Town of East Lyme. All maintenance, repair, and services such as snow removal, sanding, and sweeping of the street will be the responsibility of the abutting landowners and that certain public services may be restricted from the private street such as refuse and recycling pickup, school bus access and postal delivery."
- (H) A written agreement, which provides for the permanent, cooperative, maintenance of the private street, by the owners of the lots that are served by the private street, shall be prepared and filed in the office of the Town Clerk with the Record Subdivision Plan. Such agreement may not be amended without the prior approval of the Commission. The agreement shall require that the developer is responsible for the maintenance and insurance of the private road and all associated costs. The developer's responsibility for the private road shall continue until such time that the ownership of the private road is transferred to the owners of the lots that are served by the private road, which shall not occur until such time that the Town deems the subdivision complete, as demonstrated by the final release of security. Should the developer fail to complete the required improvements, the Commission may use the security (bonded funds) to complete the remaining work. If more than 80% of the lots have been sold, then, at the discretion of the Commission and in cooperation with the homeowners, the security may be released to the owners of the lots served by the private street for the purpose of completing the required improvements.
- (I) The words "Private Street or Road" must appear on the street signs at the intersection of all private roads.

6-10-4 Subdivision Street Construction - All subdivision streets and roadways, including private streets and roadways, shall be constructed in accordance with Section 8 of these Regulations. Construction standards for private or common driveway aprons shall also conform to the regulations set forth in Section 6-2-5 of these Regulations.

6-10-5 Access - To ensure a sufficient and continuously available method of access in the event of an emergency, the Commission shall require that subdivisions containing more than twenty (20) lots be accessible by at least two (2) points of access over existing streets, streets to be dedicated to the Town, or private streets. This requirement may be waived by the Commission in accordance with Section 4-13 of these Regulations if the Commission finds that:

- (A) The proposed subdivision provides access to an adjoining un-subdivided parcel that has access to a collector street as designated by the Plan of Conservation and Development;
- (B) Feasibility of the future connection has been adequately demonstrated and can be accomplished without an exceptional degree of site work to overcome natural topographic constraints and without significant impact on a wetland or watercourse;
- (C) The future connection will improve the safety and efficiency of vehicular traffic circulation; **OR;**
- (D) An alternative form of emergency access has been provided, which shall serve the purpose of this requirement.

Where a waiver has been granted in accord with this Section, a temporary turnaround shall be provided.

6-10-6 Where a subdivision borders an existing street with less than adequate right-of-way, and the Commission determines that there may be a need to realign or widen the street, the Commission may require the applicant to dedicate land for such future realignment or widening.

6-10-7 A minimum 25' right-of-way from the centerline of the existing street shall be provided along the frontage of the land to be subdivided. Where a subdivision borders or increases the traffic on an existing street which does not conform to Town street standards, or which is otherwise in need of improvement, and where the proposed development increases the need for improvement of the street or intersection, the Commission may require the applicant to improve the existing street or intersection to the extent that the need for such improvements or widening results from the increased traffic generation of the subdivision on such streets or intersections or to the extent necessary to provide safe and adequate access to any subdivision lot.

- 6-10-8** Where a proposed subdivision abuts an approved subdivision containing a dedicated future street right-of-way, the proposed street and all required improvements shall be constructed from the proposed subdivision street to the approved street in the existing subdivision. This requirement may be waived in accordance with Section 4-13 of these Regulations if the Commission finds:
- (A) The connection is not necessary to achieve a safe and efficient system of vehicular circulation; and
 - (B) The connection cannot be made without an exceptional degree of site work to overcome natural topographical constraints, or without significant impact on wetlands or watercourses.
- 6-10-9** Where a parcel to be subdivided abuts vacant land with a minimum of 50' frontage on an existing town road, the Commission may require an applicant to provide means of street ingress and/or egress to any adjoining property. If required by the Commission, the right-of-way for the proposed future street shall be shown on the subdivision and shall be dedicated to the Town of East Lyme.
- 6-10-10** Where a parcel to be subdivided abuts land with neither frontage nor a dedicated right-of-way onto an existing town road, the Commission may require that access be provided to the landlocked parcel through the proposed subdivision in the form of a 25' R.O.W.
- 6-10-11** Where the Commission finds that a road layout meeting the Conservation Development by Design standards will result in unnecessary disturbance of natural features with no benefit to the overall circulation and serviceability of the housing sites, the Commission may determine that a section of road need not be constructed under the following conditions:
- (A) The land previously dedicated for road right-of-way shall revert to the adjoining lots unless the Commission chooses to retain the right-of-way for future use.
 - (B) The applicant shall provide an additional 5% Open Space (not to include the eliminated road R.O.W.)
 - (C) In no case shall the decision to waive a road requirement result in a permanent cul-de-sac exceeding 2000' or serving more than 20 lots on a single cul-de-sac unless an alternate form of egress to a through road has been provided in accord with Section 6-10-5.
 - (D) Uninterrupted road lengths exceeding 1000' shall be designed to avoid a lengthy straight section to minimize potential speeding.
- 6-10-12** All street names shall be shown on subdivision plans and shall be approved by the Commission. Proposed street names shall be substantially different from any present street names in the Town of East Lyme, to avoid confusion in sound or

spelling. Streets that become extensions of existing streets shall generally bear the same name.

6-10-13 Prior to the town accepting the streets in any new subdivision, the applicant must convey by plans and deeds the rights-of-way for the streets and appurtenances to the town.

6-10-14 Where a new town road is proposed adjacent to an existing lot, the Planning Commission may require up to a 50-foot vegetated buffer to screen the new road from the existing lot. This requirement shall not apply to a re-subdivision where the original subdivision plan showed a future road.

6-10-15 The Commission may reduce any of the requirements of Sections 6-10 for public supply watershed protection, groundwater protection, aquifer protection, wetlands, and other environmental, natural, cultural, agricultural, or historic protection purposes.

6-11 RESERVE STRIP – No privately owned reserve strip shall be permitted which controls access to any part of the subdivision from any street or other open space dedicated or to be dedicated to public use.

6-12 SIDEWALK DESIGN SPECIFICATIONS

6-12-1 In all zones, except the RU-80 zone, a sidewalk shall be installed on one side of any street that functions as a collector or arterial street as designated by the average daily traffic (ADT) volume and (as specified in the East Lyme Plan of Development) in or abutting a subdivision of 10 or more lots or in any subdivision in which there are existing sidewalks within 500 feet of the subdivision boundary. The Commission may waive the requirements of this Section in accordance with Section 4-13, if the Commission finds the subdivision has been designed to provide adequate pedestrian and/or bicycle access in accordance with Section 6-12-4.

6-12-2 In any subdivision, in all zones, sidewalks shall be installed on one side of every street in or abutting the subdivision of 10 or more lots when any portion of the subdivision is within a 6,000 foot radius of any portion of a school parcel, as determined by the Commission. The Commission may waive the requirements of this Section in accordance with Section 4-13 of the Regulations.

6-12-3 The Commission may require that a sidewalk be installed on one side of any street in or abutting a subdivision which meets the location criteria of Section 6-12-1 or Section 6-12-2 but which contains fewer than ten (10) lots.

6-12-4 In any subdivision where sidewalks are required to be installed under the provisions of this Section, the Commission may permit the installation of suitably surfaced walking or bicycle paths in lieu of sidewalks, provided that such paths are located within areas of open space which provide access to street rights-of-way and open space areas and that they connect or further the future connection

of the lots within the subdivision with collector or arterial streets or with a school parcel.

6-13 STREET LIGHT SPECIFICATIONS

6-13-1 Street lighting systems shall be designed by the power company serving the area of the proposed subdivision according to the minimum standards established in the American Standard Practice for Roadway Lighting (approved by American Standards Association). It shall be the responsibility of the applicant to arrange for and pay for the installation of streetlights. All poles erected for streetlights shall be three (3) feet behind face of curb.

6-14 STREET SIGN SPECIFICATIONS

6-14-1 Street signs - Shall be installed at all street intersections in locations approved by the Commission. It shall be the responsibility of the applicant to install all street signs.

6-14-2 House numbers - Neighborhood appropriate signage containing house or unit numbers, adequate for identification in the event of an emergency response, shall be provided for flag lots at locations acceptable to the Director of Public Safety and approved by the Director of Planning.

6-15 STREET TREE SPECIFICATIONS - As a requirement of subdivision approval, the applicant shall plant shade trees along new streets, except where, in the opinion of the Commission, existing trees are to be retained by the applicant in sufficient number and location to meet the intent of this Section.

6-15-1 Location - Shade trees are to be planted on both sides of the right-of-way within five (5) feet of the right-of-way of the street or streets within and abutting the subdivision. Where required, one (1) tree shall be planted every seventy (70) feet of frontage along each street. Determination of precise locations for trees shall consider future possible locations of driveways and utility connections.

6-15-2 Size - New trees to be provided pursuant to these Regulations shall be approved by the Commission's agent, shall be nursery grown, of specimen quality, balled and burlapped, straight-stemmed, and free from disease. Such trees shall have a minimum trunk diameter (measured twelve (12) inches above ground level), of not less than two and one-half (2 ½) inches in caliper, and shall be guaranteed for one season's growth by the applicant. Only long-lived shade trees such as Sugar Maple, Pin Oak, Red Oak, London Plane, or other species acceptable to the Planning Commission, shall be planted

6-15-3 Street Tree Easement – The Subdivision plan shall reserve an easement for the planting and future maintenance of street trees a minimum five (5) feet outside of the required street right-of-way.

6-15-4 Landscaped Buffers – As required by Section 23 of the East Lyme Zoning Regulations, a wooded or otherwise landscaped buffer shall be provided along

the perimeter of the Conservation Design Development to screen development on the proposed lots from existing contiguous lots.

- (A) The minimum width of the buffer shall be 40 feet, any portion of which may be either subdivision open space area or area contained within lots (e.g. conservation easement). Where variations in topography, natural features, or compatible land uses obviate the need for such a buffer, the Planning Commission may waive or reduce these requirements if it can be shown that such a modification will further the purposes of the Conservation by Design Development.
- (B) In the case of non-wooded areas or open agrarian landscapes absent of scenic views and vistas, evergreen trees or similar vegetation (min 3-½ caliper) shall be planted to screen the proposed development from the arterial or collector road. Scenic views and vistas shall remain unblocked or uninterrupted, particularly as seen from public thoroughfares (arterial & collector road). In open agrarian landscapes, a deep “no-build, no-plant” buffer shall be maintained along the public thoroughfare where those views or vistas are prominently or locally significant. In wooded areas where the sense of enclosure is a feature that should be maintained, a deep “no-build, no-cut” buffer shall be respected, to preserve existing vegetation. Such buffer shall be a minimum of 200-feet. The Planning Commission may waive or reduce such buffer to no less than 100-feet if it can be shown that such waiver or reduction shall protect rural roadside character and improves public safety and vehicular carrying capacity by avoiding development fronting directly onto existing public roads and establishes a buffer zone along the scenic corridor or rural road with historic buildings, stone walls, hedgerows, and etc....
- (C) In either case, wooded or non-wooded areas, natural features such as existing trees, vegetation, unique site features and significant resources such as wetlands and watercourses will be retained and protected to the maximum extent practicable. The Planning Commission may require additional plantings as necessary to enhance screening in the buffer. The buffer area within forty-feet (40') of the perimeter of a CDD Development shall not be used for the placement of any above ground structures of any type.

6-16 POTABLE WATER

6-16-1 Water Supply - A potable, adequate, and dependable water supply shall be provided for every lot.

6-16-2 Private Well Water – A private well shall be permitted provided that (1) topographic and geological condition are satisfactory; (2) each well can be designed, located and constructed in accordance with the standards and

requirements of the Connecticut Department of Health; and (3) each well shall have the approval of the Town of East Lyme Health Department.

6-16-3 Public Water Supply

- (A) Unless the East Lyme Water and Sewer Commission certifies to the Planning Commission that it is not in the best interests of the Town of East Lyme, any non-residential subdivision or a subdivision of ten (10) or more lots which has a boundary within a 1,500 foot radius of the East Lyme Water and Sewer Department supply system shall be required to provide a piped water distribution system designed to serve the entire subdivision and extend to the boundary in the direction of anticipated supply with valved and capped or plugged end(s) to be provided by the applicant for ready future connection(s).
- (B) The design of any public water system within the Town of East Lyme shall be in conformance with the East Lyme Water and Sewer Department specifications as approved by the East Lyme Water and Sewer Commission.
- (C) No proposal for a development using water supplied by a company incorporated on or after October 1, 1984, shall be approved by the Planning Commission unless such company has been issued a certificate pursuant to Connecticut General Statutes Section 16-262m.
- (D) Any planned public water supply system which has a potential surface reservoir site with an estimated dependable yield of more than 500,000 gallons per day or one or more potential wells and an established confined yield of fifty (50) or more gallons per minute shall be reviewed by the Southeastern Connecticut Regional Water Authority, pursuant to Special Act 381 of the 1967 Session of the Connecticut General Assembly.
- (E) Notwithstanding the provisions of Section 6-16-3(A) of these Regulations, the Planning Commission shall not accept applications for non-residential subdivisions or subdivisions of ten (10) or more lots which propose the use of water supplied by the East Lyme municipal water system. The amendment shall be effective for a period of time beginning on the effective date of this amendment and ending on July 1, 2000 or when the Planning Commission is notified by the East Lyme Water Sewer Commission that there is a supply of municipal water sufficient to serve said subdivisions, whichever date shall first occur.

6-17 UNDERGROUND UTILITIES

6-17-1 Underground electric transmission lines, telephone lines and cable television lines shall be installed in each proposed subdivision, unless a waiver is granted in accordance with Section 4-13 of these Regulations. In determining the feasibility of underground installation, the Commission shall refer to the detailed soils survey prepared by the USDA Soil Conservation Service, information on the subdivision plan, site investigation by the Town Engineer and consultation with the authorized representative of the utility or telephone company.

6-18 SURETY

6-18-1 The Planning Commission may require surety (e.g. performance and maintenance bonds or letters of credit), sufficient to ensure compliance and completion of site improvements with an approved subdivision or resubdivision and any conditions placed thereon. Bonded improvements may include but are not limited to, erosion and sedimentation control measures, drainage, landscaping buffers, utilities, parking, recreational facilities, streets, private streets or roadways, driveways, and sidewalks, or other elements as approved by the subdivision or resubdivision plan. Surety requirements shall conform to the requirements of Section 8 of the East Lyme Subdivision Regulations.

SECTION 7 - OPEN SPACES AND EASEMENTS

7-1 PURPOSE - To provide meaningful open space areas within private developments and encourage site development sensitive to the area's natural characteristics.

7-2 GENERAL - The Planning Commission shall require the provision of this section in the subdivision of any parcel of 10 acres or more in area or any subdivision of 4 or more lots. The Planning Commission may apply these provisions to subdivisions of less than 4 lots. In determining the appropriateness of an open space and/or recreation area and whether public access shall be required, the Commission shall consider Plan of Development map designations and the subject site's characteristics with respect to the following objectives:

- (A) Protect surface and subsurface water resources and provide for public access where appropriate.
- (B) Expand existing open space.
- (C) Assemble open corridors or greenbelts by providing linkages to existing open space or connecting nodes of development, trails, wildlife corridors or riparian buffers.
- (D) Protect critical or threatened habitats with emphasis on those areas identified in Connecticut's Natural Diversity Database and Endangered Species List.
- (E) Protect groundwater within existing or potential public drinking water supply aquifers.
- (F) Protect natural drainage ways.
- (G) Protect lands and features of cultural importance including archeological and historical sites.
- (H) Provide sites for active and passive recreation of a non-commercial nature.
- (I) Protect unique and significant natural features including wetlands, floodplains, prime agricultural soils, scenic vistas, trap rock ridges, shorelines and tidal marshes.
- (J) Preserve farmlands and productive forestland.
- (K) Preserve areas that shape community design and character i.e. buffer strips, landscaped areas visible from main roads, walkways, community gateways.
- (L) Protect steep slopes to control soil erosion and water runoff as well as maintaining scenic views of and from areas such as bluffs, ridges, river ways, etc.

7-2-1 For Conventional Subdivisions, (less than 4 lots or less than 10 acres) dedication of open space shall be in an amount not less than ten (10) percent of the gross land area of the subdivision, unless waived in accordance with Section 4-13 of these regulations. For Conservation Design Development Subdivisions, designation of open space shall be in accord with the standards set forth in Section 23.6 of the Zoning Regulations.

- 7-2-2** If a parcel, or abutting parcels under common ownership, is subdivided in stages, the open space dedication attributable to the subdivision of a portion of the entire tract may, at the Commission's discretion, be deferred to a later date when more or all of the land remaining in the entire tract is subdivided. If approved by the Commission, the following notation shall be placed on the approved map: "The open space dedication attributable to the land depicted on this map is hereby deferred to a later date when some, or all of the remaining land is re-subdivided. At such later date, the open space attributable to this subdivision will be combined with the open space dedication(s) attributable to the remaining portion(s) of the entire tract in a size and at a location determined by the Commission in accordance with the requirements set forth in the Subdivision Regulations.
- 7-2-3** No more than fifty (50) percent of the open space land may be covered by water or classified as inland or tidal wetlands.
- 7-2-4** No open space parcel or contiguous conservation easement area shall be less than one acre unless it meets the total open space requirements for the subdivision.
- 7-2-5** The Commission may require access ways to open space areas used for the purpose of active or passive recreation to be graded and improved in a manner suitable for safe pedestrian and/or vehicular traffic. Access roadways which are intended to accommodate vehicular traffic shall have a right-of-way no less than 50' with a traveled way of 20'. The slope of an access roadway shall not exceed 12%. Parking may be required to accommodate the number and types of vehicles expected to use the facility. Pedestrian easements or access ways shall be no less than 15' wide.
- 7-2-6** Land to be provided as open space for the purpose of conservation and protection of wildlife and natural or scenic resources shall typically be left in a natural state. Except for improvements approved by the Commission, open space areas shall not be graded, cleared, or used as a repository for brush, stumps, earth, building materials or debris.
- 7-2-7** All site improvements proposed for open space shall be shown on the subdivision plans.

7-2-8 The Planning Commission may waive the open space requirements if the subdivision is to contain affordable housing, as defined in CGS Section 8-39a, equal to 20% or more of the total housing to be constructed in such subdivision.

7-3 CONVEYANCE OF OPEN SPACE – The Planning Commission shall determine the most appropriate method of conveyance after considering: the relationship of the subject area(s) and its specific characteristics to the Plan of Development and the objectives cited in Section 7-2; the desirability and suitability of public access and use, and the scope of the subdivision proposal. The following options for conveyance may be utilized by the Commission:

- (A) Perpetual dedication to the Town;
- (B) Perpetual dedication to the State of Connecticut;
- (C) Perpetual dedication to the East Lyme Land Trust or other private organization whose purpose is the preservation of historic and natural sites for the public benefit and use;
- (D) Dedication to a Homeowner’s Association formed under the Common Interest Ownership Act (CIOA);
- (E) Utilization of Conservation Easements, with or without public access;
- (F) Utilization of a Recreation Easement;
- (G) Private Ownership with the appropriate taking of development rights by a public entity (state or town);
- (H) Any combination of the above or any suitable alternative approved by the Commission.

7-3-1 If an applicant proposes dedication of Open Space to the State of Connecticut, the East Lyme Land Trust, or any other private organization, a letter from an authorized agent for the State or private organization, stating its willingness to accept the open space, shall be included with the application.

7-4 LEGAL TRANSFER OF OPEN SPACE – Properly executed legal documents, including warranty deeds for any title transfers, shall be prepared in accordance with the provisions of this section and shall be submitted in triplicate with the final subdivision maps to be filed. All documents must be acceptable to the Town Attorney and/or the Commission and shall refer to the approved subdivision map by title. All warranty deeds for the dedication of land to the Town shall be held in escrow by the Commission to be recorded on the land records upon acceptance by the Board of Selectmen. If the Board of Selectmen chooses not to accept the open space, the deed shall be returned, and the applicant shall return to the Commission for determination of an alternative means of preserving the open space. In no case, shall the acceptance of any deed by the Commission

or an employee of the Town be deemed as acceptance of the open space and/or recreation area by the Town.

SECTION 8 - SUBDIVISION IMPROVEMENT SPECIFICATIONS

8-1 GENERAL – Subdivision improvements shall conform to the State of Connecticut Department of Transportation Standard Specifications Form 816, as revised, and shall be installed by the applicant according to the following specifications.

8-2 MONUMENTS AND MARKERS - Monuments shall be set at corners and angles of all streets and at all points of curvature and points of tangency of curved streets. Monuments shall be set at corners of public easements dedicated to the town. Monuments shall be set plumb, in line with street lines one (1) inch above finished grade. They shall be of granite or pre-cast reinforced concrete, not less than four (4) inches square and thirty (30) inches long, with a brass or copper plug or with a cross marking the center of the four (4) inch square. No open holes in monuments will be permitted. No permanent monuments shall be installed until all construction which could destroy or disturb the monuments is completed. Permanent monuments and corner pins shall be set prior to a written formal request to the Commission for acceptance of the public improvements. For subdivisions which do not require the construction of public improvements, no building permit shall be issued until monuments and corner pins have been set. In addition, written certification by a licensed land surveyor shall be submitted to the Commission and the Town Engineer indicating that the monuments and the corner pins have been set in accordance with the approved plan.

8-3 STREETS

8-3-1 General - The entire area of right-of-way shall be cleared of trees, roots, boulders, ledge and any other unsuitable materials, except that the Commission may direct that certain existing trees be left standing which will not interfere with the installation of utilities, the maintenance of sight lines, and provision for snow shelves at the recommendation of the Town Engineer.

8-3-2 Rights-of-Way - The traveled portion of the right-of-way shall be constructed to a width of twenty (20) feet between curbs for a light residential street permitting traffic in one direction, twenty-eight (28) feet between curbs for a light residential, residential and collector street, forty-six (46) feet for an arterial street. The traveled portion of the right-of-way of streets in non-residential subdivisions shall be constructed to a width not less than twenty-eight (28) feet between curbs, and the Commission may require a greater width upon recommendation of the Town Engineer. The traveled portion shall be centered in the right-of-way with a three-eighth (3/8) inch to one foot crown, except with special permission of the Town Engineer.

All streets shall be constructed in accordance with the Typical Cross Section provided in Appendix A. Waiver of this requirement may be granted in accord with Section 4-13 under the following conditions:

- (A) Where an extension of an existing street is proposed the width of which is less than the widths specified in this section, or
- (B) Where a stormwater management system utilizing Best Management Practice (BMP) methods for controlling runoff and encouraging infiltration has been incorporated in the design at the recommendation of the Town Engineer. The BMP methods shall include but not be limited to the minimization of impervious surfaces, minimization of curbing and collection, the use of grass or vegetative filter zones, landscape depressions, slotted curb spacers, perforated pipe for conveying storm water, establishment of buffers from streams, wetlands and waterbodies, and any combination of methods, where appropriate. The BMP's employed shall be designed in accordance with the latest update of the CTDEP Stormwater Quality Manual.

- 8-3-3 **Arterial Streets** - If required by the Commission, arterial streets shall have a right-of-way of not less than eighty (80) feet.
- 8-3-4 **Collector Streets** - Collector streets shall have a right-of-way of not less than sixty (60) feet.
- 8-3-5 **Residential Streets** - Residential streets and light residential streets shall have a right-of-way of not less than fifty (50) feet.
- 8-3-6 **Temporary Turnarounds** - Where a temporary turnaround is provided on a street that is to be extended in the future, the fifty (50) foot street right-of-way to the subdivision boundary shall be deeded to the town, and the segments of the turnaround outside the fifty (50) foot street shall be deeded to the abutting lot owners subject to an easement to the town for street purposes. When such street is extended beyond the turnaround, the applicant shall remove the road constructed in the segments of the temporary turnaround, place curbing, fill with earth and loam and seed in an appropriate manner. The owner and developer of the subdivision shall obtain a permit as required by Town Ordinance and shall provide a separate cash bond to ensure satisfactory completion of the removal of the temporary turnaround as designed in the Construction Sequence Report (Section 4-2-13). Removal of the temporary turnaround shall be in accordance with the Construction Sequence Report and as directed by the Town Engineer. Removal of the temporary turnaround will be scheduled and performed with minimal impacts upon adjoining property owners.

8-3-7 Dead-End Streets - Permanent dead-end streets shall terminate in a circle not less than fifty (50) feet in radius to the outside of the right-of-way, of which not less than forty (40) feet in radius shall be constructed and surfaced. Permanent dead-end streets shall include an island centered in the turnaround, provided that such island does not constitute a lot and provided that it is left in a naturally vegetated state or improved with landscaping to be maintained by a homeowner's association. The length of cul-de-sac and total number of lots served shall not exceed the following:

	<u>Max. Length</u>	<u>Max. # Lots</u>
Standard Residential	700'	12
Cluster / Open Space	1000'	15

The length of a permanent dead-end street shall be measured from the edge of pavement of the through street with which it intersects, along the centerline of the dead-end street and across any center island in a straight line to the outside edge of pavement of the turnaround.

8-3-8 Block Length - For conventional subdivisions, the maximum uninterrupted length of any through street between points of intersection with other through streets shall be 1500 feet. For open space/cluster subdivisions in the Rural or Greenway Conservation districts, the maximum uninterrupted length of any through street between points of intersection with another through street shall be 5000 feet.

8-3-9 Turnaround - The turnaround portion of a permanent dead-end street having a center island shall be designed for one-way traffic with a travel surface twenty (20) feet in width. The Commission may permit a loop street in lieu of a cul-de-sac. The distance along the centerline from the mid-point of the loop street to the edge of pavement of the through street with which it intersects shall not exceed 1500 feet and the number of lots served shall be not more than twenty (20).

8-3-10 Minimum Grades - Each local street shall have a minimum grade of at least 1.5 percent and a maximum grade of not more than ten (10) percent. Each collector street shall have a minimum grade of at least 1.5 percent and a maximum grade of not more than eight (8) percent and each arterial shall have a minimum grade of at least 1.5 percent and a maximum grade of not more than five (5) percent.

8-3-11 Centerlines - Centerlines of alternate side streets shall not be closer than 125 feet measured along the centerline of the principal street. Residential and light residential street centerlines shall have radii in excess of 150 feet. Road centerlines for collector streets shall have radii in excess of 300 feet. The tangent distance between reverse curves shall not be less than 100 feet. Collector and

arterial street centerlines shall be designed so that a minimum of residential properties face onto them.

8-3-12 **Intersections** - Unless waived by the Commission, in accordance with Section 4-13 of these Regulations because of topography or other conditions, all streets shall join each other so that for a distance of at least 100 feet the street is at right angles to the street it joins.

8-3-13 **Corners** - Corners shall be rounded with a radius of not less than thirty (30) feet at the curb line if the intersection occurs at a right angle.

8-4 STREET BASE CONSTRUCTION

8-4-1 All streets shall be graded to their full width in accordance with the Typical Cross Section provided in Appendix A.

8-4-2 The subgrade of the paved area shall be thoroughly compacted to grade.

8-4-3 Whenever the subgrade is unstable and material is removed to necessary depth to ensure stability, the subgrade shall then be reestablished with gravel or other suitable material.

8-4-4 Boulders or broken ledge one cubic yard or greater in size shall not be used for fill within the right-of-way of subdivision streets, however, such rock may be used as fill if approved by the Town Engineer.

The roadbed shall consist of the following:

(A) 12" of bank run gravel

(B) 4" of processed gravel

(C) 3 ½" compacted thickness of bituminous concrete installed in two (2) layers. **Base course shall be 2" and top course shall be 1 ½".**

(D) In rock cuts, twenty-four (24) inches of bank run gravel is required. Processed gravel shall conform to the requirements stated in the State of Connecticut Department of Transportation Standard Specifications Form 816, as revised. All gravel is to be placed in compacted lifts of 6 inches.

8-4-5 Both layers of bank run gravel and processed gravel shall be properly graded to the elevations and crown as shown on the approved plans and each layer shall be wetted down and thoroughly compacted through the use of a ten (10) ton roller or equivalent.

8-4-6 Additional sub drainage shall be installed when and where deemed necessary by the Town Engineer at the time of construction. The cost of such improvements shall be borne by the applicant.

8-5 STREET SURFACING

- 8-5-1** Applicants are strongly urged to complete the placing of hot bituminous concrete before November 1. However, paving may be permitted after that date provided the outside air temperature is above forty (40) degrees Fahrenheit measured in the shade and the surface temperature is above thirty (30) degrees. Paving will not be permitted after the first weekday in December unless warranted by extraordinary circumstances and specifically authorized in writing by the Town Engineer.
- 8-5-2** After surfacing, six (6) inches of machine-formed bituminous curbing shall be laid on the finished road surface with a distance as specified in Appendix A between faces of opposite curbings. No curbing shall be required in driveway areas, but in its stead a ten (10) foot bituminous concrete apron shall be constructed with a one and one-half (1-½) inch lip and with an upward grade of six (6) inches. **If top course is not installed within 5 days of base course, a 7" temporary curb must be installed on base course.**
- 8-5-3** The area between curbing and property lines shall be loamed to a depth of four (4) inches from the top of curbing and graded with a cross slope of one-half (1/2) inch to one foot toward road. **Permanent vegetative cover shall be established in accord with the latest update of the CT Guidelines for Soil Erosion and Sediment Control.**

8-6 SIDEWALKS

- 8-6-1 Public Sidewalks** - All public sidewalks shall be concrete. All sidewalks at street intersections shall be designed and constructed to provide a ramp and such shall meet the following specifications: (1) The cut shall have a surface that is textured and non-slip; (2) the cut shall be at least thirty-six (36) inches wide; and (3) the cut shall have a slope not greater than one inch per foot and shall be beveled at the bottom. Sidewalks shall be a minimum of four (4) feet in width and shall be located within the street lines with one edge 1'-0" from the property line. The sidewalk shall be laid on a six (6) inch bank run gravel base, tamped and rolled, and shall be constructed of air entrained concrete, four (4) inches thick, having an ultimate strength of 3,000 pounds per square inch and having expansion joints with pre-molded fillers spaced every twenty (20) feet and suitable weakened plain joints. The Town Engineer may require increased slab thickness and/or steel reinforcing at driveway crossings. Sidewalk width may be waived by the Commission in accordance with Section 4-13 of these Regulations.
- 8-6-2 Private Sidewalks** - All private sidewalks shall be designed to utilize permeable surfaces such as pervious concrete , concrete block pavers, flexi-pave, or other material satisfactory to the Town Engineer, Town Planner, and as approved by the Commission. Stone dust and items such as gravel shall not be used.

8-7 STREET LIGHTING – A minimum standard street lighting system shall be installed by the power company serving the area of the proposed subdivision with the cooperation of the applicant. The cost for the installation of any type of lighting fixtures and pole shall be paid by the applicant. The developer shall bond such lighting facilities with all other subdivision improvements.

8-8 STREET SIGNS – All street signs shall be installed according to the following standards:

8-8-1 Posts – Shall be a minimum of nine (9) feet long, two-and-one-half (2-½) inch IPS steel standard weight pipe which shall be set in a concrete block sixteen (16) inches square by twelve (12) inches deep. The post shall be covered with a post cap for a two and one-half (2 ½) inch (I.D.) pipe. Posts shall be painted green.

8-8-2 Street signs – Shall be six (6) inches wide by twenty-four (24), thirty (30), or thirty-six (36) inches depending upon the length of the name and placed seven (7) feet above grade. The material used shall be .080, 6061-T6 aluminum mounted in a criss-cross assembly.

8-8-3 Letters – The size of primary copy shall be four (4) inches. The size of suffix copy shall be two (2) inches. The letter shall be colored black on a white background on reflector type finish.

8-9 DRAINAGE

8-9-1 The construction of the drainage system including methods of construction and quality of materials used shall be in conformity with the Construction Plan and shall conform to the Connecticut Department of Transportation Standard specifications Form 816, as revised. The installation shall be inspected and approved by the Town Engineer prior to back filling.

8-9-2 Minimum stormwater drainpipe size shall be fifteen (15) inches in diameter and shall be reinforced concrete pipe or equivalent as approved by the Planning Commission. There shall be a minimum of twenty-four (24) inches of cover over all drainage pipes. In general, all storm sewers shall be constructed of reinforced concrete pipe class IV, unless a higher classification is necessary due to the height of fill. Asphalt-coated corrugated metal pipe will be used on grades of ten percent (10%) or greater, or where there is a poor foundation condition. The proper gage is to be selected from the height of fill table in the Department of Transportation Drainage manual.

8-9-3 Pre-cast catch basin tops shall be used over solid concrete wall construction. Pre-cast sumps shall be used.

8-9-4 Open ends of all drainage installations shall be protected by poured concrete end walls or other approved structures.

- 8-9-5 Earth drainage channels shall be planted with suitable vegetative cover. If required by the Commission drainage channels shall be covered with riprap or paved.
- 8-9-6 The proposed drainage facilities shall be designed with regard for ultimate development within the drainage basins. The cost of installing oversized drainage system shall be borne by the applicant.
- 8-9-7 A settling basin may be required by the Town Engineer if it is deemed necessary to prevent silting of streams, wetlands, or other areas contiguous to the drainage outfall. All storm sewer outlets within easements on private property shall be piped at least 100 feet beyond the street line unless otherwise directed by the Planning Commission.
- 8-9-8 Drainage easements shall be a minimum of twenty (20) feet wide and shall be located entirely on one of any two abutting lots.
- 8-9-9 The applicant shall acquire all drainage rights and shall be responsible for connecting all new drainage to an existing, adequate town drainage system or to an existing natural watercourse where drainage rights have been acquired.
- 8-9-10 Where a subdivision is traversed by a watercourse, drainage way, channel, or stream, the Commission may require that there be provided a stormwater easement or drainage easement of adequate width to conform substantially to the lines of such watercourse.

8-10 WATER SYSTEM

- 8-10-1 A proposed subdivision that is required to have a public water supply shall comply with the East Lyme Water and Sewer Commission specifications for materials of construction and installation.
 - 8-10-2 The principal water main or mains in any subdivision shall be sized to provide for future expansion, except within coastal waterfront areas, where mains shall be designed to accommodate existing land uses only. The size of all mains shall be approved by the East Lyme Water and Sewer Commission.
- 8-11 SEWERAGE SYSTEM** – Where applicable, any planned sewerage system, whether public or private, shall be installed in accordance with the Construction Plan and shall be in conformity with these Regulations and the Public Health Code of the State of Connecticut, and as approved by the Town department or corporation having jurisdiction. In areas to be sewerred, the sanitary sewer pipes shall be installed and capped.

8-12 UNDERGROUND UTILITIES - Unless a waiver is granted in accordance with Section 4-13 of these Regulations, underground utilities shall be installed. Underground electric transmission, cable television and telephone lines shall be installed by the utility and Telephone Company in cooperation with the applicant and in accordance with the specifications of the utility and telephone company. In determining the location of the underground lines the standards established in Appendix A shall be used as a guideline. All underground utilities shall be installed prior to street paving. Easements for utilities shall be placed along lot lines and shall be at least (15) feet wide.

8-13 FIRE PROTECTION – Where public water is available or required, fire hydrants may be required where necessary to insure public health and safety. Fire hydrants normally shall be located no more than five hundred (500) feet apart and shall be approved by the Water and Sewer Department. To eliminate future road openings, all underground utilities for fire hydrants, together with the hydrants, shall be installed before any final paving of a road shown on the subdivision plan.

In subdivisions where public water is not and will not be available, the Planning Commission may require the provision of alternative sources of water supply, such as a pond or cistern with dry hydrant connections, if it finds that the size of the proposed subdivision requires such a supply for fire protection purposes in order to insure public health and safety.

8-13-1 In subdivisions with ten (10) lots or more having structures of 2,800 square-feet or less and located outside a public water supply area, there shall be a minimum 30,000 gallons of accessible firefighting water within 2,200 feet of each lot. In any subdivision or portion of any subdivision having structures greater than 2,800 square-feet, the minimum water supply for fire fighting shall be satisfactory to the Fire Marshall, and approved by the Commission. It shall be the responsibility of the applicant to notify the Fire Marshal of any application made under this Section and notice shall be sent by Certified Mail within seven (7) days of the submission of an application to Department of Planning.

8-13-2 Any impounded water supply, such as a cistern, tank, or other approved storage facility, shall contain a minimum of 30,000 usable gallon. The supply shall allow the fire department to withdraw water at a rate not less than 1,000 gallons per minute at a maximum 15-foot lift using standard firefighting equipment. The facility shall be designed to have adequate year round access from a public street.

8-14 PRIVATE STREETS AND ROADWAYS – The traveled portion of the right-of-way may be constructed to a width of eighteen (18) feet between curbs for a light residential street permitting traffic in two directions. The Commission may require a greater width upon recommendation of the Town Engineer. Private streets or roadways, shall have a right-of-way of not less than fifty (50) feet. Common access drives shall have a right-of-way of not less than twenty-five (25) feet.

8-14-1 Private Streets or Roadways shall provide under drain in all road cuts or as directed by the Town Engineer. A note shall be added to all site plan sheets indicating that "Under drain may be subtracted or added by the Town Engineer at the time of construction, based on field conditions"

SECTION 9 - ASSURANCES FOR COMPLETION AND MAINTENANCE OF IMPROVEMENTS

- 9-1 BONDS** – In lieu of requiring the completion of all improvements for the final approval of a subdivision plan, the Commission may accept a bond in an amount and with surety or other security and conditions satisfactory to it.

The bond shall secure to the town the actual construction and installation of such improvements and utilities within one (1) year from the day of approval of the subdivision Plan. The Commission may extend the completion date for public improvements for additional periods. As a condition for such extension, the Commission may require the increase in the amount of the bond.

- 9-2 EROSION AND SEDIMENTATION CONTROL AND SITE RESTORATION BOND** – The Commission may accept a bond in an amount and with other security and conditions satisfactory to it to secure erosion and sedimentation and site restoration as described in Sections 4-4-6, 5-3-1(C), 5-7, and 8-3-6.

- 9-3 APPLICABILITY** - These bond requirements shall apply to improvements shown on the approved plans whether the streets are to be public or private, except that no maintenance bond shall be required for private improvements.

- 9-4 BOND FORM** – Bonds shall be duly executed on forms provided by the town and available from the Planning Department, with proper reference to all maps and plans showing the streets, drainage, and other improvements covered by the bond. To ensure the completion of all required improvements, including storm drainage system, erosion and sedimentation control measures, roads and pavements, sidewalks and curbs, trees, grading, setting of monuments, and any other requirements made as a condition for subdivision approval or depicted on the endorsed Record Subdivision Plan, Plan and Profile Plan, Grading Plan, Erosion and Sedimentation Control Plan, the Commission shall require, prior to the release of the signed Approved Maps (Mylar copy) any one of the following:

9-4-1 A deposit of cash with the Town, of an amount satisfactory to the Town Engineer and approved by the Commission which, will cover the cost of the improvements.

9-4-2 A security agreement, in a form acceptable by the Commission, which provides that no lots may be sold, or building permits issued until such time that all required improvements are complete, or cash deposited, as outlined in Section 9-4-1 for the remaining improvements.

9-5 FAILURE TO COMPLETE IMPROVEMENTS – Where a bond has been posted and required improvements have not been installed within the terms of such bond, the town may thereupon declare the bond to be in default and require that all the improvements be installed regardless of the extent of the building development at the time the bond is declared to be in default.

9-6 PARTIAL RELEASE – When the Town Engineer determines, based on site inspection and certification by the applicant's engineer that a substantial portion of the public improvements called for in the final plan approved by the Commission have been completed, a recommendation may be made for one or more partial releases of a portion of the surety, the balance to be sufficient to guarantee completion of the public improvements. Such partial release shall be authorized by the Planning Commission upon recommendation of the Town Engineer. Releases shall be granted in amounts of no less than \$1,000. In no event shall a bond be released below two percent (2%) of the actual cost of improvements or no less than \$3,000, whichever is greater.

9-6-1 Bond Reduction Schedule for Private Roads

<u>First Release</u>	Clearing Sanitary Sewer Storm Drainage Utilities Subgrade Base Material	BOND REDUCTION As Recommended by Town Staff and Approved by the Commission
<u>Second Release</u>	Binder Course Curbing Sidewalk Erosion and Sedimentation Control (Site Stabilization)	BOND REDUCTION As Recommended by Town Staff and Approved by the Commission
<u>Final Release</u>	Turf Establishment Street Trees Top Course As Built Drawings Surveyor's Certification Removal of All Unauthorized Objects from Rights-of-Way Deeds Street Signage	BOND REDUCTION As Recommended by Town Staff and Approved by the Commission

9-7 **FINAL RELEASE** – Bonds will not be released until the following conditions have been met:

- (A) The Town Engineer has submitted a certificate stating that all required improvements have been satisfactorily completed;
- (B) The applicant's engineer or surveyor has certified to the Town Engineer, through submission of detailed as-built plans that the layout of the line and grade of all public improvements is in accordance with the Construction Plan for the subdivision. As-built plans shall include a Grading Plan and a Construction Plan as described in Section 5 of these Regulations. Such plans shall show any modification or changes made during construction.
- (C) All public improvements called for in the final plan have been accepted by the town. A maintenance bond, as described in Section 9-8-1 shall be filed with the town.
- (D) All conditions and requirements of the Commission's approval of the subdivision application have been satisfied.
- (E) The deed to all roads has been accepted by the town.

9-8 **MAINTENANCE OF IMPROVEMENTS** – The applicant shall be required to maintain all improvements and provide for snow removal on streets until acceptance of said improvements by the town.

9-8-1 **Maintenance Bond** – The applicant shall be required to file a maintenance bond with the Town prior to the acceptance of the improvements, in order to assure the satisfactory condition of the required improvements, for a period of one (1) year after the date of acceptance of the improvements by the town. The maintenance bond shall be in an amount equal to two percent (2%) of the cost of improvements and shall be of such form as described in these Regulations. Pursuant to Section 9-3 of these Regulations, no maintenance bond shall be required for private improvements.

9-8-2 **Snow Plowing and Other Maintenance** - In the case of conditional or final approval a cash bond in the amount of \$10,000 or five percent of the cost of improvements excluding utilities not intended to be conveyed to the town, whichever is the greater amount, shall be posted with the Town of East Lyme. Such bond shall be accompanied by an agreement under which the Director of Public Works may draw on such funds, after adequate notice, to effect snow plowing or other maintenance necessary for the public health, safety and convenience. Such monies may also be used to pay any electrical charges necessary for street lighting. The extent of such payments to the Town shall be specified in the agreement with the Town of East Lyme.

9-9 MAINTENANCE SERVICES TO BE PROVIDED TO SUBDIVISION RESIDENTS ON UNACCEPTED STREETS

9-9-1 Services – It shall be the responsibility of the applicant to provide snow removal, ice removal and garbage collection services for all residents in the subdivision until such time as the streets are accepted by the Town of East Lyme. Said services are to be provided in the same degree as is normally provided by the Town of East Lyme to residents living on an accepted street.

9-9-2 Building Permits – No building permits shall be issued by the Building Inspector of the Town of East Lyme for the occupancy of any house or building in any subdivision when the street on which the house or building is located has not been accepted by the Town of East Lyme unless all of the following conditions have been met:

- (A) A determination has been made by the Town Engineer that the unaccepted street has been sufficiently developed and identified by temporary or permanent street signs to permit access for the provision of municipal services in a manner normally done by the town and that safe access to each dwelling can be obtained from the street by both emergency apparatus and the occupants of the dwelling. At a minimum, the street shall be improved with the required processed gravel base up to the lot for which a building permit is requested.
- (B) The applicant has posted a surety or cash performance bond with the Town of East Lyme to guarantee the providing of garbage collection and the removal of snow and ice in the same degree as is normally provided by the Town of East Lyme to residents living on town accepted streets. The amount of said bond will be determined by the Commission based on the recommendations of the Town Engineer.
- (C) The applicant has provided the Commission and the Town Engineer, in writing, the name, address, and telephone number of the person or persons who will perform the garbage collection, snow removal, and ice removal services. Further, the Commission and the Town Engineer shall be informed, in writing, of any changes in the name, address, and telephone number of the person or persons performing these services.

SECTION 10 - SUPERVISION OF IMPROVEMENTS

10-1 INSPECTION OF PROPOSED STREETS – Work on succeeding stages of construction shall not proceed until inspection and approval has been obtained from the Town Engineer. At least twenty-four (24) hours notice shall be given to the Town Engineer when requesting an inspection. Inspection of proposed streets shall be made at the below stated points of construction by the Town Engineer.

- (1) Inspection of proposed street area prior to any construction.
- (2) Inspection of roadway excavation prior to drainage provisions.
- (3) Inspection of subgrade.
- (4) Inspection of gravel subbase following the placement of each six inch compacted lift.
- (5) Inspection of rolled gravel base prior to placement of hot asphalt concrete surface.
- (6) Inspection of the placement of bituminous concrete pavement.
- (7) Final inspection before submission to the Board of Selectmen.

10-2 PROFESSIONAL INSPECTION OF IMPROVEMENTS – The Town Engineer shall inspect all improvements. Before the release of any required bond or cash deposit, the Town Engineer shall certify to the Commission that the work performed by the applicant under the terms of such bond, has been completed in substantial compliance with the subdivision plan.

10-3 INSPECTION OF PUBLIC WATER SYSTEM – When the subdivision requires installation of a public water system, such system must be inspected during construction and approved by the East Lyme Director of Public Works.

10-4 INSPECTION OF EROSION SEDIMENT CONTROLS

10-4-1 Inspections – Inspections shall be made by the Commission or its designated agent during development to ensure compliance with the certified erosion and sediment control plan, and to ensure that the control measures and facilities are properly installed, functioning and maintained. The Commission may require the applicant to verify through progress reports that the soil erosion and sediment control measures and facilities have been performed or installed according to the certified plan and are being operated and maintained.

10-4-2 Variations – The Commission or its designated agent may approve variations in materials and methods to control soil erosion and sedimentation as shown on the certified plan which do not result in any changes to or extensions of the disturbed area, and are substantially consistent with the certified plan. The Commission’s designated agent may require that such are necessary to control soil erosion and sedimentation in compliance with the certified plan; the cost of which shall be borne by the applicant. All inspection reports shall specify actions taken pursuant to this section.

SECTION 11 - ENFORCEMENT

11-1 GENERAL ENFORCEMENT - If the Commission determines that the requirements of these Regulations, or the provisions of any plan approved or certified by the Commission are not being adhered to, the following action shall be taken:

11-1-1 The Commission shall notify the owner or applicant of the violation by sending a letter to such person by registered or certified mail, return receipt requested, explaining in detail the violation and the corrective measures necessary. The letter shall specify a reasonable time for the implementation of the corrective measures.

11-1-2 If the corrective measures called for by the Commission have not been implemented within the period specified, the Commission, through its designated agent, shall issue a Cease and Desist Order, effective in a specified reasonable time by registered or certified mail, return receipt requested. In the event there shall be an outstanding surety bond, a copy of such notice shall be set in the same manner to the surety and to such other persons as the Commission may deem appropriate.

11-1-3 If the Cease and Desist Order issued by the Commission is not obeyed within the period specified, the Commission shall refer the matter to the Town's counsel for obtaining a restraining order against the violation.

11-1-4 Nothing in this section shall be deemed to exclude any other remedy or relief available to the Commission by law or in equity.

11-1-5 Nothing in this section shall be deemed to preclude conferences and negotiations between the Commission and any owner or applicant with respect to any alleged violations.

11-2 ENFORCEMENT OF EROSION AND SEDIMENT CONTROLS - If the Commission or its designated agent determines that the requirements of the certified soil erosion sediment control plan are not being adhered to, the following action shall be taken:

11-2-1 Violations - The Commission or its designated agent shall notify the applicant of the violation of the certified plan by transmitting a copy of the inspection report prepared on site to the applicant, retaining a copy of such inspection report for subsequent action as provided herein. The Commission or its agent shall specify the corrective measures necessary to comply with the certified plan as determined during the inspection. In those cases where corrective measures are mutually agreed to, the inspection report shall detail such measures, time period in which they will be implemented (not to exceed forty-eight (48) hours from time of inspection) and shall have the signature of the Commission's agent and the applicant.

11-2-2 Cease and Desist Orders - When determined by the inspecting agent that the provisions of the certified plan are not being adhered to and no mutually agreeable solution or measure to correct such violation is obtained with the applicant, or such solution has not been implemented within a forty-eight (48) hour time period, the inspecting officer shall issue a Cease and Desist Order, effective immediately, in writing with a copy of the inspection report to the applicant, contractor, responsible agent and the surety company. The Order shall provide no more than forty-eight (48) hours in which to correct such violation and shall act as notice to the Surety Company, contractor and applicant of the Town's intent to cause the required repairs to be made and bill the contractor, applicant and surety company for the cost of the work then involved. Such action shall be done without prejudice to any other remedy available to the Town. As long as the Cease and Desist Order remains in effect, no new building permits for lots within the entire subdivision shall be issued and no Certificate of Occupancy shall be issued if such structure is within a lot or such lot is affected by the violation as determined by the Commission or its agent.

APPENDICES

APPENDIX A - Typical Road Cross Section

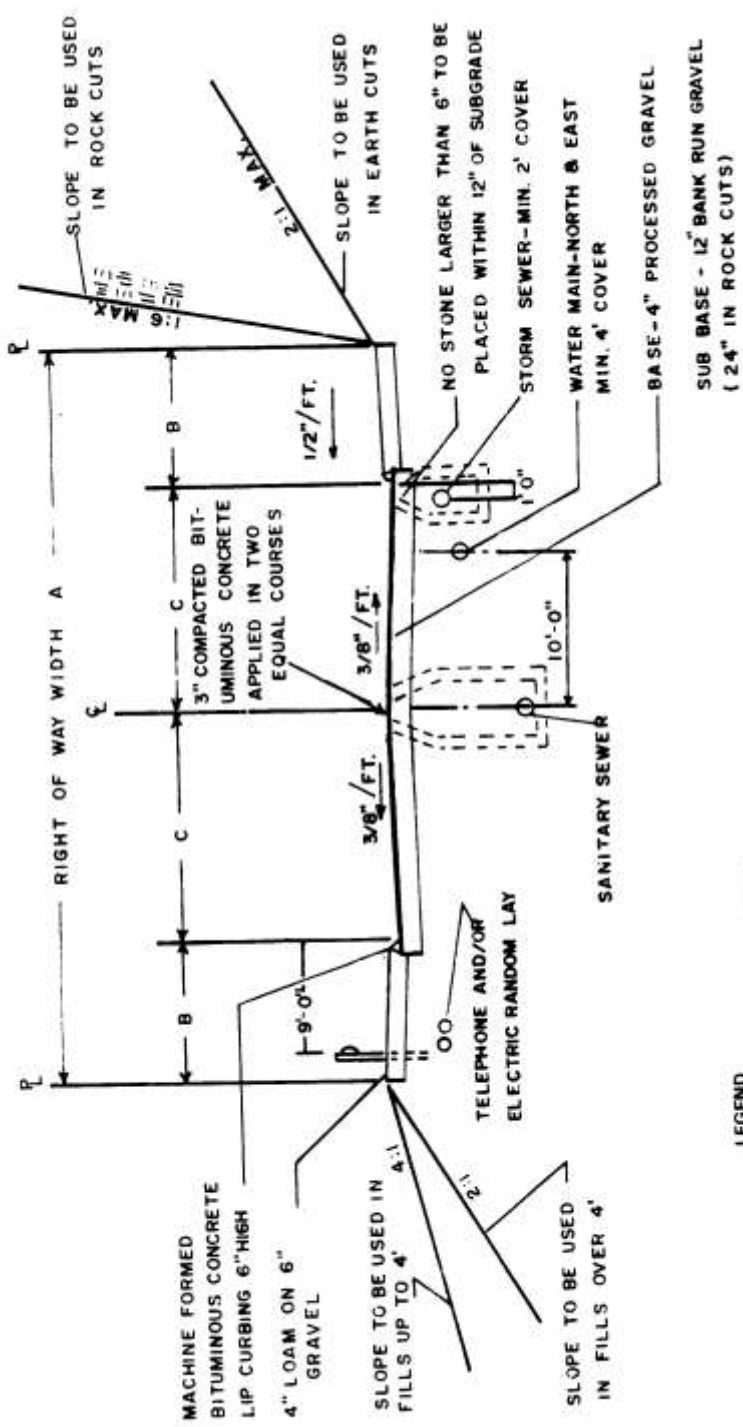

APPENDIX A

NOTE: For slopes greater than 4:1, RB beam rail on W150x13 posts shall be installed. Installation shall conform to Conn. DOT standards unless otherwise approved by the Town Engineer.

LEGEND

TYPE OF STREET	A	B	C
LIGHT RESIDENTIAL (ONE WAY)	50	15	10
LIGHT RESIDENTIAL	50	11	14
COLLECTOR ROAD	60	16	14
ARTERIAL	80	17	23

TYPICAL CROSS SECTION

NOT TO SCALE

APPENDIX B – Reserved for Future Use
This page intentionally left blank.

APPENDIX C – Site Testing

A. Deep Test Pits:

1. Minimum of one per lot, additional pits as required by the East Lyme Health Department.
2. Pits dug in area of the proposed sewage system and located on the Record Subdivision Map by surveying.
3. Pits to be dug to approximately eight (8) feet deep, or four (4) feet below the bottom of the proposed leaching system, whichever is greater.
4. The following information shall be submitted on the Sanitation Report and plan:
 - a. Soil types encountered including the depth of each horizon. Hardpan, compacted or impermeable layers shall be noted.
 - b. Date of testing.
 - c. Depth to ground water.
 - d. Depth to ledge rock.
 - e. Any other information which may affect the operation or installation of a subsurface sewage disposal system.

B. Percolation Tests:

1. Minimum of one per lot, additional tests as required by the East Lyme Health Department.
2. Percolation tests conducted in the area of the proposed system. Multiple tests may be required if the proposed system spans different soil textures or horizons which may adversely affect the design seepage rate. The seepage rate of the lower soil layer shall be utilized as the basis of design for the system.
3. Test holes shall be located on the map by surveying.
4. Tests shall be conducted according to State of Connecticut Public Health Code, Section 19-13-b10d (b).
5. The following information shall be submitted with the plan:
 - a) Date of testing
 - b) Stabilized percolation rate (i.e. minimum uniform rate rather than average of drop).

C. Other Tests

1. Such other tests as may be required by the East Lyme Health Department including, but not limited to, permeability tests, sieve analysis, and hydraulic analysis, in order to determine the suitability for on-site sewage disposal.

APPENDIX D – Standard Details

Drawing

- 1 Standard Endwall and Wing Type Endwall
- 2 Type "C" Catch Basin
- 3 Type "C-L" Catch Basin
- 4 Type "C-G" Catch Basin
- 5 Type "D-G" Endwall
- 6 Type "C-L" Catch Basin Double Grate
- 7 Manhole
- 8 Underdrain, Ditch and Curb
- 9 Baffle Box
- 10 Riprap Channel or Ditch

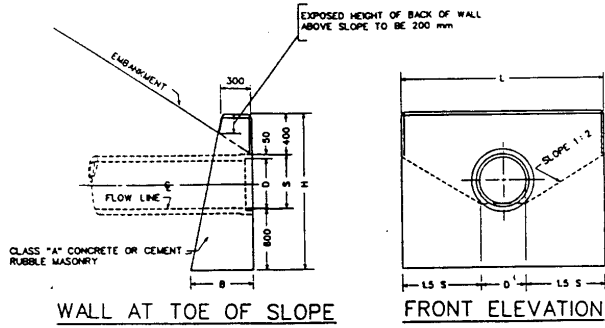

DIMENSIONS AND QUANTITIES FOR ONE ENDWALL BASED ON S - D = 50

D	S	H	L	BATTER	B	VOL.
mm	mm	mm	mm	v-h	mm	m ³
300	350	1350	1350	5:1	570	0.8
375	425	1425	1650	5:1	590	1.0
400	450	1450	1750	5:1	590	1.1
450	500	1500	1950	5:1	600	1.4
600	650	1650	2550	5:1	630	2.1
750	800	1800	3150	5:1	660	2.7
800	850	1850	3350	5:1	670	2.9
900	950	1950	3750	4:1	790	4.2
1000	1050	2050	4150	4:1	810	4.7*
1050	1100	2100	4350	4:1	820	4.9*
1200	1250	2250	4950	4:1	860	6.1*

* VOLUME BASED ON "D" AND WALL THICKNESS AT $\frac{1}{2}$ OF PIPE BEING DEDUCTED

STANDARD ENDWALL

- H = TOTAL HEIGHT OF ENDWALL
- B = BASE
- D = INSIDE DIAMETER OF PIPE
- S = HEIGHT OF SLOPE ABOVE FLOW LINE AT FACE OF WALL - MINIMUM = D + 50
- L = LENGTH OF WALL - 3S - D

NOTES:

1. ALL CONSTRUCTION DIMENSIONS ARE NOMINAL.
2. WHEN ONE ENDWALL IS TO BE USED FOR TWO PIPES, THE DIMENSIONS OF THAT ENDWALL SHALL CONFORM TO THAT REQUIRED FOR THE LARGER PIPE, EXCEPT THE DIMENSION "L" SHALL BE INCREASED BY THE OUTSIDE DIAMETER OF THE SMALLER PIPE PLUS 300 mm.
3. THESE ENDWALLS WILL BE USED ONLY AT LOCATIONS WHERE THEY WILL NOT BE A HAZARD TO VEHICLES THAT RUN OFF THE ROAD. IN NO CASE WILL THE LOCATION BE WITHIN THE CLEAR ZONE. SEE CONNECTICUT DESIGN MANUAL.
4. ALL REBARS ARE METRIC DESIGNATIONS.
5. ALL EDGES OF EXPOSED SURFACES TO BE CHAMFERED APPROXIMATELY 25 mm.

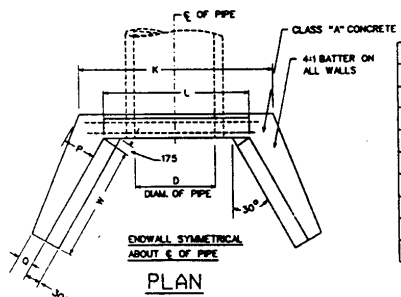

DIMENSIONS AND QUANTITIES FOR ONE WING TYPE ENDWALL

D	B	C	G	H	K	L	P	Q	R	W	VOL.
mm	mm	mm	mm	mm	mm	mm	mm	mm	mm	mm	m ³
900	460	610	990	2030	2780	2200	430	250	1040	1670	4.5
1000	460	610	990	2180	3010	2300	470	250	1180	2030	5.1
1050	460	610	990	2180	3010	2350	470	250	1180	2030	5.1
1200	480	760	1140	2490	3300	2500	540	290	1450	2380	7.0
1500	480	760	1140	2790	3770	2800	620	290	1750	3060	9.5
1600	480	760	1140	2790	3770	2900	620	290	1750	3060	9.5
1800	480	760	1140	3100	4230	3100	690	290	2060	3790	12.5

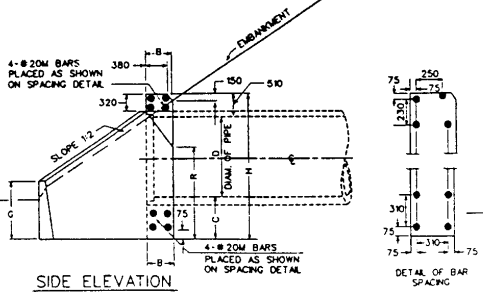
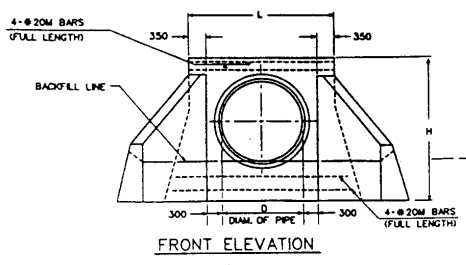

NOTE:
COST OF REINFORCING BARS TO BE INCLUDED IN THE CONTRACT UNIT PRICE FOR CLASS "A" CONCRETE

STANDARD WING TYPE ENDWALL
REINFORCEMENT TO BE PLACED FOR 1200 mm PIPE AND UP

**STANDARD DETAIL
ENDWALL AND WING TYPE ENDWALL**

DRAWING #1

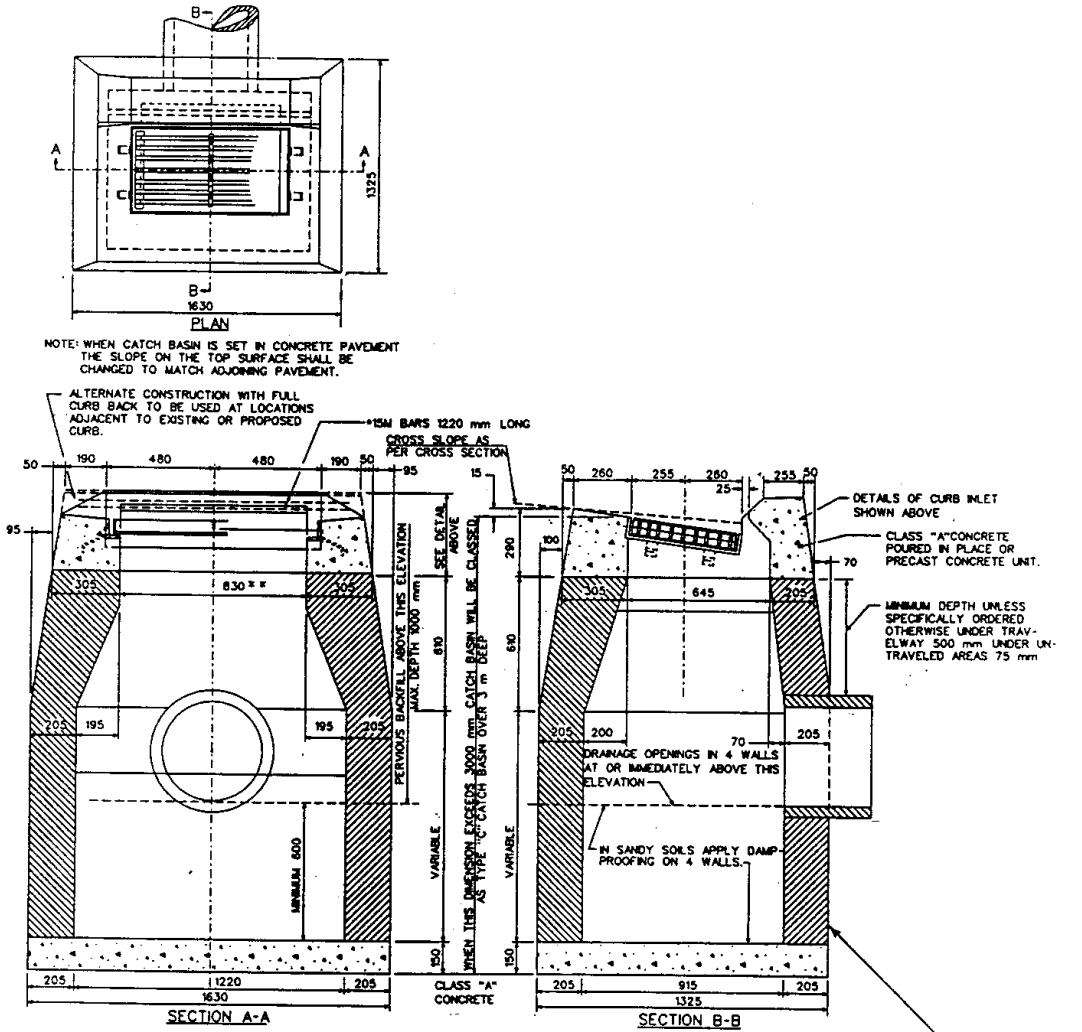

PRECAST CONCRETE UNITS, BRICK, CLASS "A" CONCRETE, MASONRY CONCRETE UNITS, WHERE BRICK OR MASONRY CONCRETE UNITS ARE USED, CORBELLING WILL BE PERMITTED. MAXIMUM CORBEL TO BE 75 mm. NO PROJECTION SHALL EXTEND INSIDE OF LIMITS NOTED BY **

STANDARD DETAIL
TYPE "C" CATCH BASIN

DRAWING #2

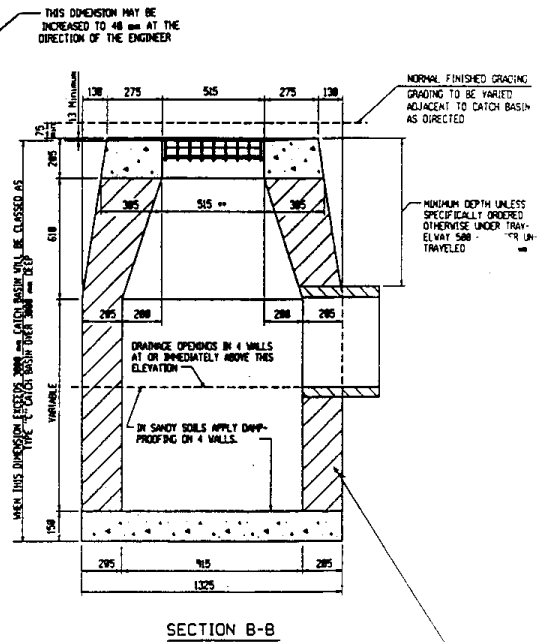
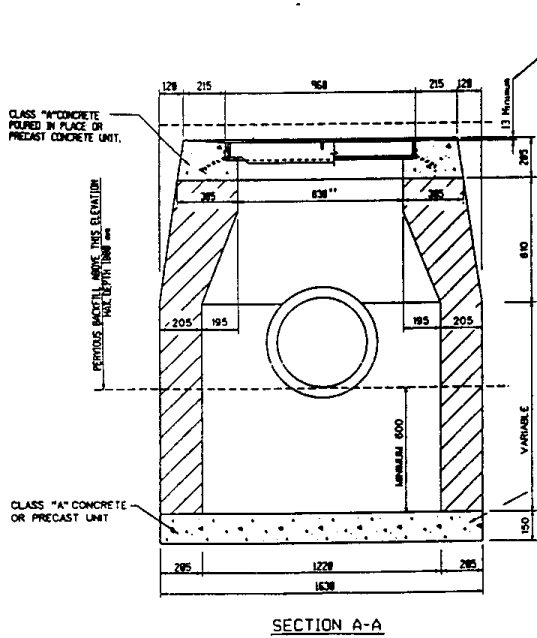
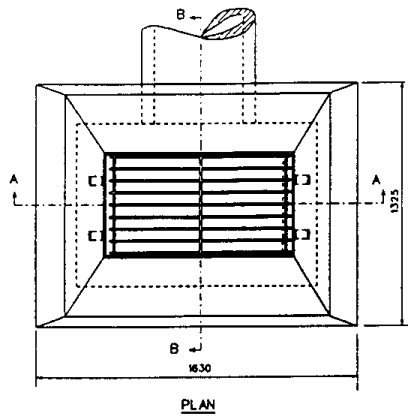

PRECAST CONCRETE UNITS BRICK, CLASS "A" CONCRETE, MASONRY CONCRETE UNITS, WHERE BRICK OR MASONRY CONCRETE UNITS ARE USED CORRELLING WILL BE PERMITTED. MAXIMUM CORREL TO BE 75" NO PROJECTION SHALL EXTEND INSIDE OF LIMITS NOTED BY **

STANDARD DETAIL TYPE "C-L" CATCH BASIN

DRAWING #3

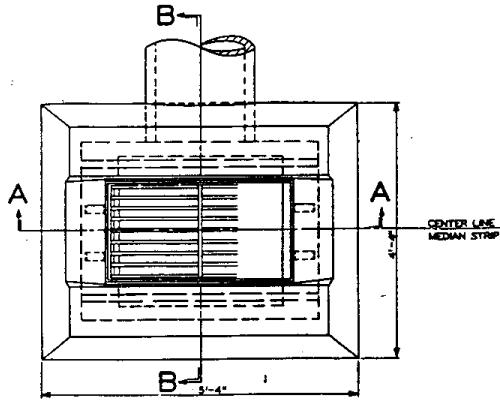

PLAN
TYPE "C-G" CATCH BASIN & TYPE "C-G" DROP INLET

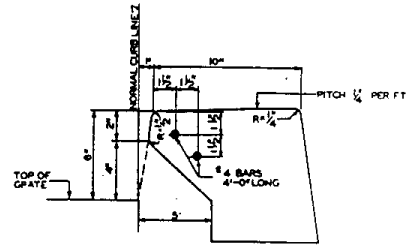

DETAIL OF CURB TYPE INLET

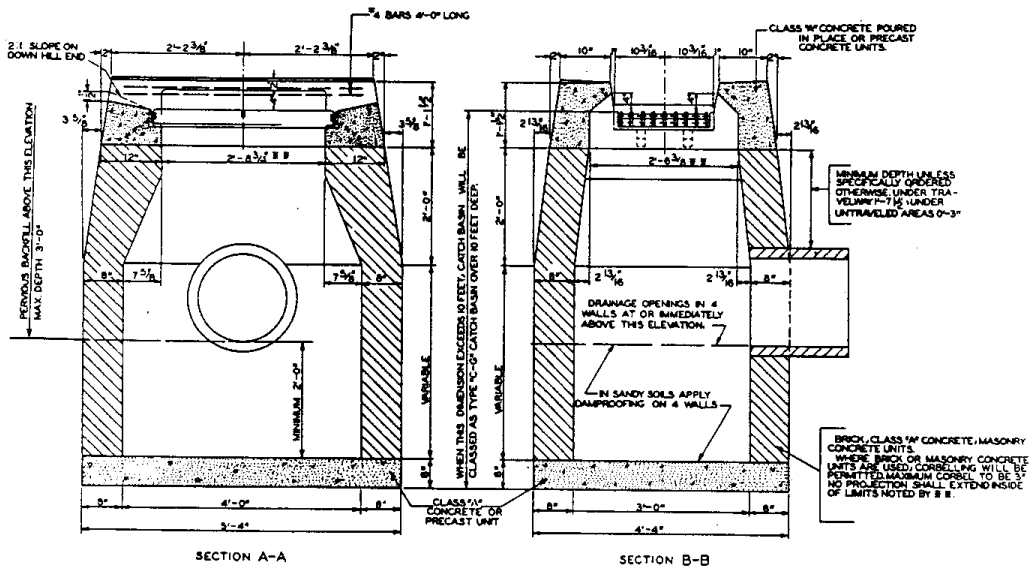

SECTION A-A

SECTION B-B

WHERE PRECAST CONCRETE UNIT IS USED FOR SLUMP,
THE TOP OF THE UNIT SHALL BE AT LEAST 8\"/>

STANDARD DETAIL
TYPE "C-G" CATCH BASIN

DRAWING #4

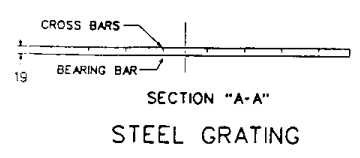
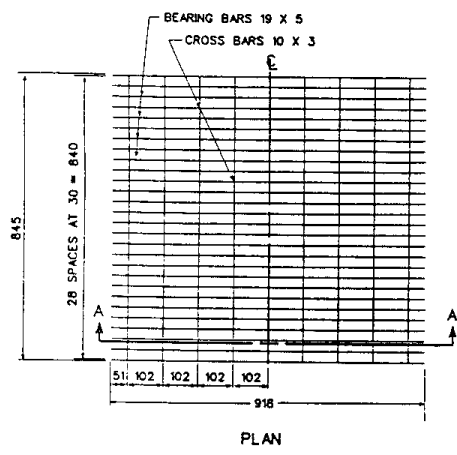
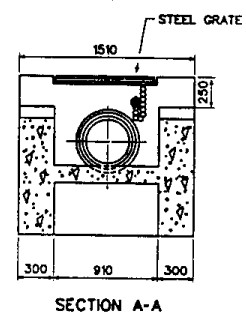
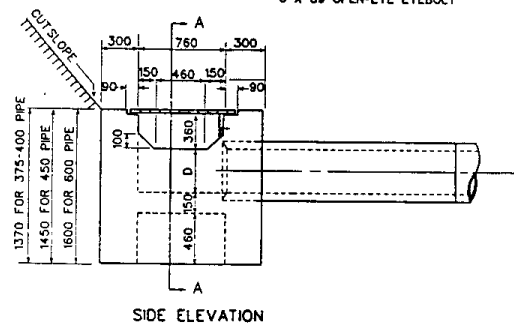
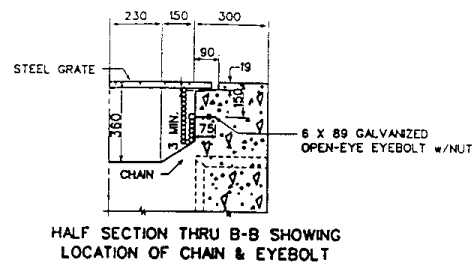
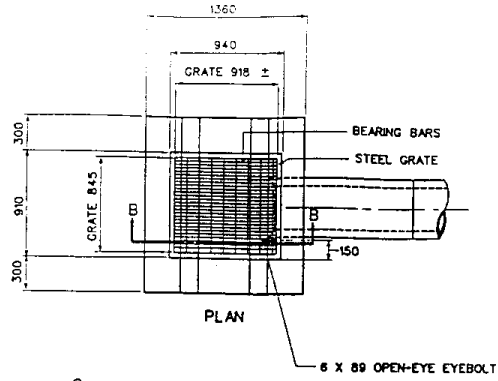

GENERAL NOTES

1. THESE ENDWALLS WILL BE USED ONLY AT LOCATIONS WHERE THEY WILL NOT BE A HAZARD TO VEHICLES THAT RUN OFF THE ROAD. IN NO CASE WILL THE LOCATION OF THESE ENDWALLS BE WITHIN THE CLEAR ZONE. SEE CONNECTICUT DESIGN MANUAL.
2. FOR ALL TYPE "D-G" & "L" ENDWALLS, ALL EDGES OF EXPOSED SURFACES TO BE CHAMFERED APPROXIMATELY 25 mm.
3. ALL CONSTRUCTION DIMENSIONS ARE NOMINAL.
4. IN CONSTRUCTING TYPE "D-G" ENDWALLS, CARE MUST BE TAKEN TO HAVE THE SHORT AXIS OF THE WELL OPENING PARALLEL TO THE LONG AXIS OF THE GRATE IN ORDER TO ALLOW THE BEARING BARS TO PERFORM THEIR FUNCTION PROPERLY.
5. TYPE "D-G" AND "L" ENDWALLS TO BE CONSTRUCTED OF CLASS "A" CONCRETE OR CEMENT RUBBLE MASONRY.
6. STEEL GRATING MECHANICALLY LOCKED UNDER HYDRAULIC PRESSURE, WELDED, OR ELECTROFORGED. APPROXIMATE MASS = 20 kg. THE GRATE SHALL BE GALVANIZED IN ACCORDANCE WITH M.06.03.

TYPE "D-G" ENDWALL	
PIPE DIAMETER (mm)	VOLUME (m ³ CLASS "A") CONCRETE
375-400	1.9
450	2.0
600	2.2

STANDARD DETAIL TYPE "D-G" ENDWALL

DRAWING #5

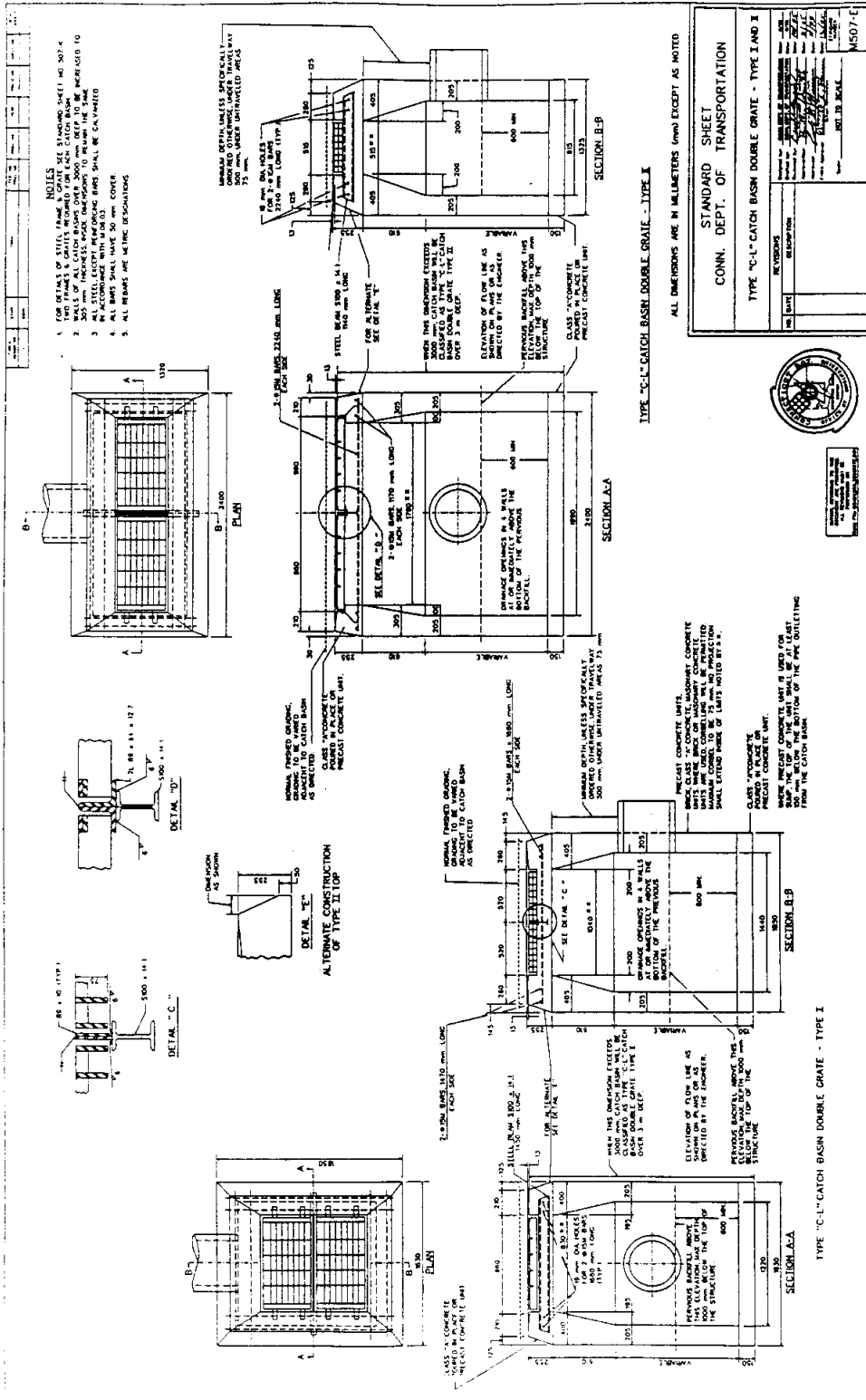

DRAWING #6

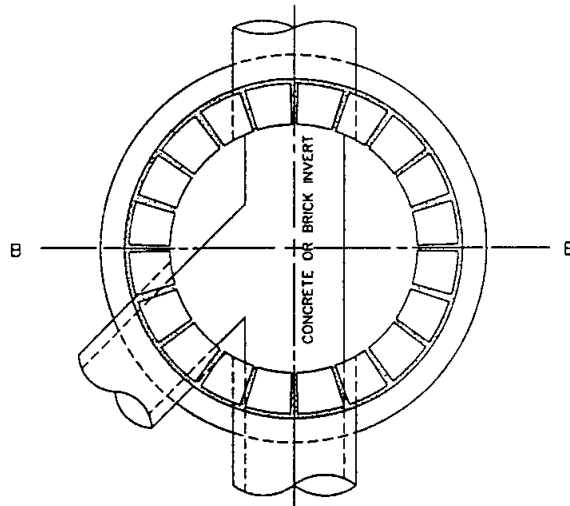

CROSS SECTION B-B

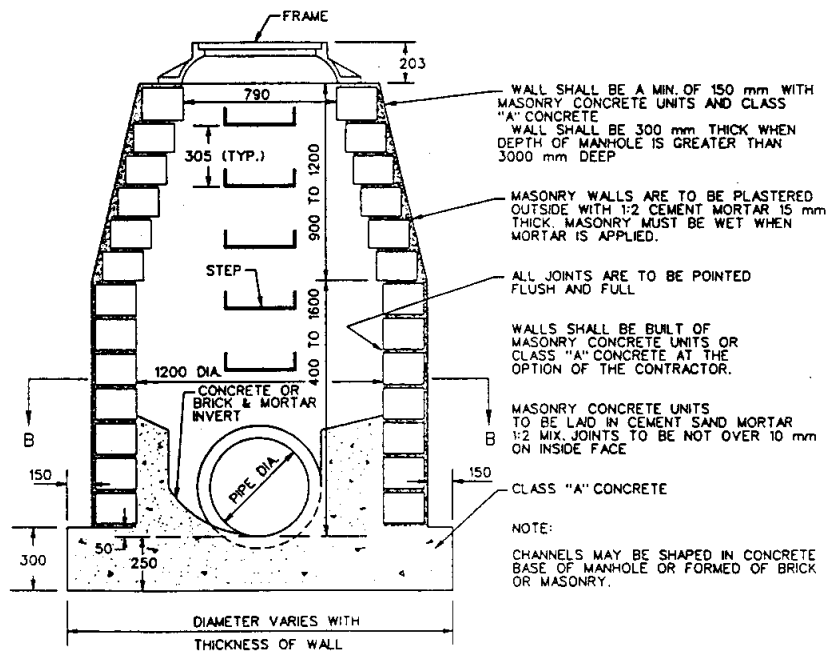

VERTICAL SECTION

MASONRY CONCRETE UNITS
OR CLASS "A" CONCRETE

**STANDARD DETAIL
MANHOLE**

DRAWING #7

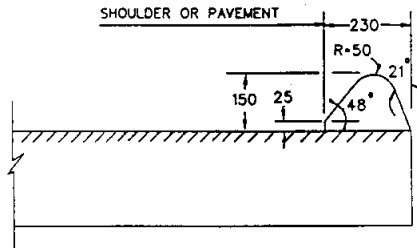
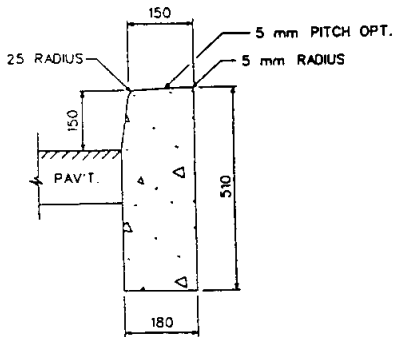
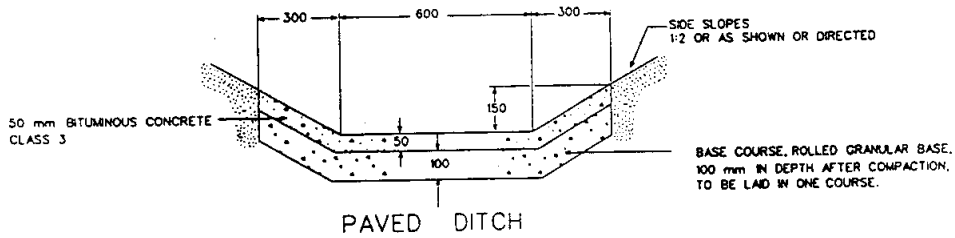
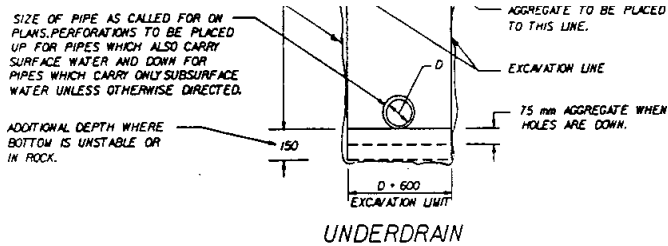
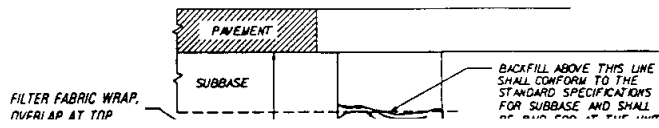

STANDARD DETAIL
UNDERDRAIN, DITCH AND CURB

DRAWING #8

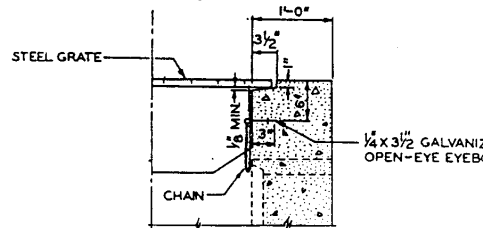
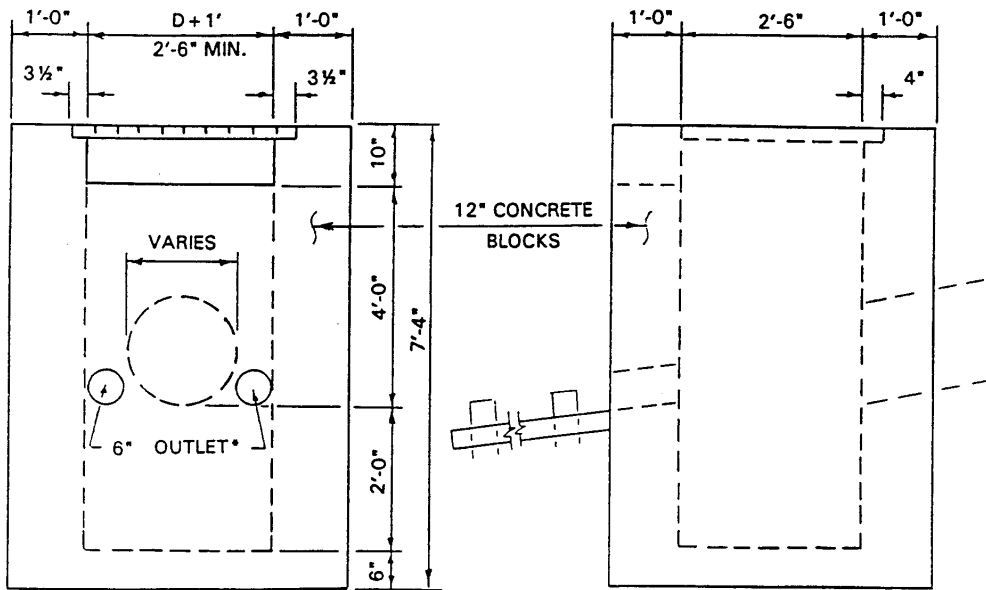
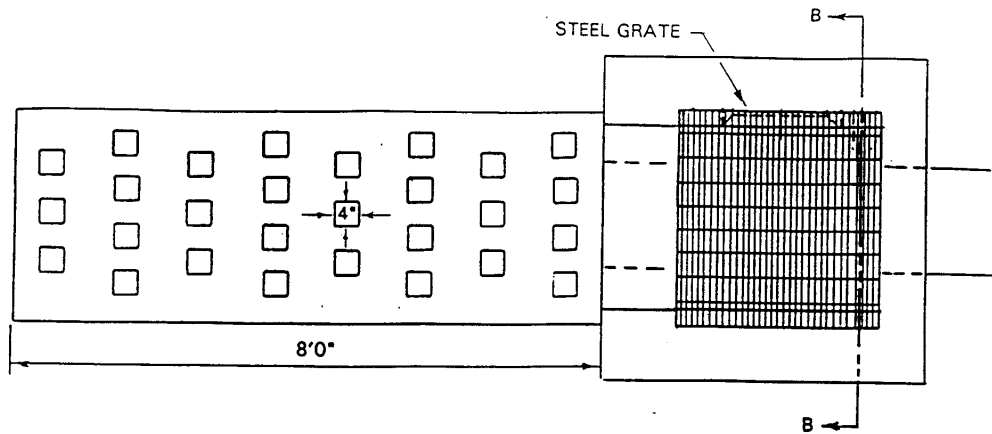

*INCREASE TO 10" FOR INLETS
OVER 24" DIAMETER.

ONE BLOCK ON EACH SIDE OF BOTTOM OF
SUMP TO BE SET ON SIDE TO PROVIDE FREE DRAINING.

HALF SECTION THRU B - B SHOWING
LOCATION OF CHAIN & EYEBOLT

STANDARD DETAIL
BAFFLE BOX

DRAWING #9

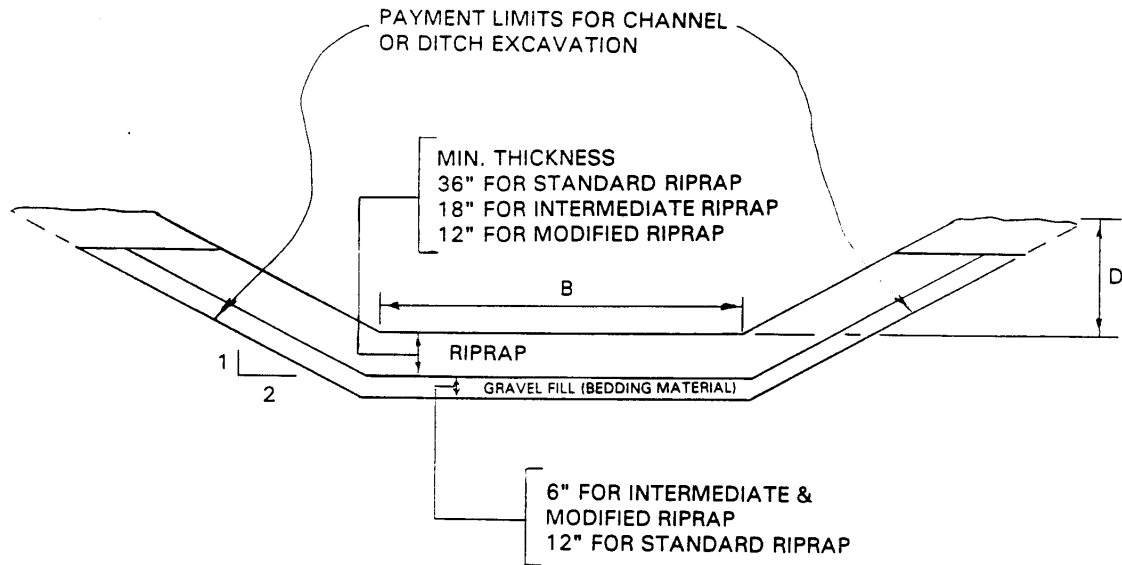

NOTE:

"D" - DEPTH AS SHOWN ON PLANS
 "B" - WIDTH AS SHOWN OF PLANS

STANDARD DETAIL
 RIPRAP CHANNEL OR DITCH

DRAWING #10

APPENDIX E – Application Fee Calculation Sheet

2.1 Subdivision Application Review. For subdivisions and re-subdivisions, the following fees shall be paid at the time of application to the Planning Commission:

2.1.1	# Lots _____ X \$100.00	_____
2.1.2	Base Fee	\$750.00
2.1.3	Public Hearing Fee, if applicable (\$1250.00)	_____
2.1.4	Design Review Fee -LF new road _____ X \$1.00	_____
2.1.5	Professional/Legal Consultations (actual cost)	_____
2.1.6	State of Connecticut Fee	\$60.00
SUBTOTAL		_____

2.2 Subdivision Application Processing and Inspection. Upon approval of a subdivision/ re-subdivision by the Planning Commission, the following fees shall be paid prior to the Chair’s signing the approved subdivision plan:

2.2.1	# Lots _____ X \$100	_____
2.2.2	Base Fee	\$100.00
2.2.3	Road/Utility Document Review Fee (\$400.00)	_____
2.2.4	Inspection Fee - LF of new road _____ X \$1.00	_____
2.2.5	E & S Control Fee - # Lots _____ X \$50.00	_____
SUBTOTAL		_____

2.3 Coastal Area Management Review

Lots _____ X \$10.00 (\$25.00 min.) _____

2.4 Application for Revision of Lot Line \$150.00

TOTAL FEES _____

Fees based on Section 2 of the Town Ordinance Establishing Schedule of Fees for Conservation Planning and Zoning Commissions as amended.

APPENDIX F – Declaration of Restrictions and Covenants

**DECLARATION OF RESTRICTIONS AND COVENANTS REGARDING
SALE OR TRANSFER OF SUBDIVISION LOTS**

THIS DECLARATION; executed this day of , 200 , by

(Hereinafter referred to as “Grantor”) in favor of THE TOWN OF EAST LYME PLANNING COMMISSION, (hereinafter referred to as “Grantee”) with respect to the property shown on a map or plan entitled, “

(Hereinafter referred to as the “Subdivision”)

WHEREAS, the above referenced Subdivision plan was approved by the East Lyme Planning Commission on , and

WHEREAS, said approval was conditioned upon the completion of the public improvements and other items; and

WHEREAS, the molars of said Subdivision plan have been endorsed by the Chairman or Secretary of the Planning Commission and recorded on the East Lyme Land Records (Drawer/Map); and

NOW THEREFORE, the Grantor hereby covenants and agrees as follows:

1. No lots in the above referenced Subdivision shall be sold or offered for sale or otherwise transferred until the following requirement(s) have been met, and a release of this Declaration shall have been executed by the Chairman or Secretary of the East Lyme Planning Commission:

A. The completion and acceptance by the Town of East Lyme of all public improvements, or in lieu thereof, the posting of a performance bond in such amount and such form as shall have been approved by the East Lyme Planning

Commission with surety and conditions satisfactory to it securing to the

municipality the actual construction, maintenance and installation of such public improvements within the period specified in the bond.

2. In the event that it should be necessary for the Town of East Lyme or its Planning Commission to take action at law or in equity to enforce the provisions of this Declaration, the Grantor shall pay the Town's expenses for such action, including but not limited to reasonable attorney's fees. The Grantor also agrees that a violation of this Declaration may be enforced by injunction, and that should the Town seek relief by way of a temporary or permanent injunction, it shall not be required to demonstrate irreparable injury and lack of an adequate remedy at law.
3. The provisions of this Declaration shall be binding upon the Grantor and his successors and assigns.

Witness

By _____

Its

Witness

STATE OF CONNECTICUT)

) ss. East Lyme

COUNTY OF NEW LONDON)

Personally appeared _____, as aforesaid, signer of the foregoing instrument, and acknowledged the same to be his/her free act and deed as such _____

and the free act and deed of said commission, before me, this _____ day of _____, 20____ .

Commissioner of the Superior Court

Notary Public

My Commission Expires:

STATE OF CONNECTICUT)

) ss.

COUNTY OF)

On this _____ day of _____, 20__ , before me, the undersigned officer, personally appeared _____ and acknowledged the same to be his free act and deed and the free act and deed of said corporation as _____ of said limited liability company.

Commissioner of the Superior Court

Notary Public

My Commission Expires:

APPENDIX G – Signature Block for Final Mylars

APPROVED BY THE EAST LYME PLANNING COMMISSION

Chairman/Secretary: _____

Approval Date: _____

Filing Deadline: _____

Expiration Date: _____

APPROVED	EFFECTIVE	SECTIONS	DESCRIPTION	L.N.	T.C.
08/13/02	09/07/02	6-13-6	Back Lots		
11/19/02	01/01/03	10	Open Space		
01/06/04	02/01/04	4-3-3, 4-3-4, 4-10, 4-1-4, 4-7	Extensions Fees, Lot Line Rev.		
03/02/04	04/01/04	6-9 (1-12), 7-3-6	Streets		
05/03/05	06/01/05	3-5, 4-1-1, 4-3-6, 4-3-8, 4-7	Aquifer, Conditional Approval Lot Line Rev., Sig. Block		
09/06/05	10/01/05	6-9-2, 6-9-10	Unnecessary Roads		
10/18/05	11/08/05	1-2, 4-1, 5-11, 6-9, 614	Design Standards for the Protection of Natural & Cultural Resources		
04/06/06	05/01/06	6-14-6	Back Lots		
05/02/06	05/31/06	4-3-6	Conditional Approval		
10/03/06	11/01/06	7-3-2, 7-3-8, 7-4-5 7-5-2, 7-5-3, 7-9-1, 6-11, 5-1-3, 5-2-1, 5-2-2 & 5-2-10	Road Standards	10/21/2006	10/20/2006
11/13/07	11/30/07	3-5	Subdivision Moratorium		
09/03/08		7-3-7	Subdivision Improvement		
10/24/08	11/28/08	1-2 (19,20), 4-1-4(l), 5-7, 6-16, Appendix B	Stormwater Management	11/25/08	

2/1/11	2/1/11	Sections 1, 2, 3, 4,5,6,7,8,9,10,11, and Appendices.	Comprehensive Rewrite Conservation Development by Design Subdivision	2/5/11	
--------	--------	--	---	--------	--